



# INSTALLATION GUIDE

## RESYSTA SIDING ON SOFFITS AND CEILING

### QUIK-TRIM SYSTEM



### I. Introduction

#### SECTION 1

Material Components

#### SECTION 2

Basics

#### SECTION 3

Scope of Profiles

### II. Installation Procedure

#### SECTION 1

Review the Reflected Ceiling Plan

#### SECTION 2

Battens Substructure

#### SECTION 3

Trim and Accessory Options

#### SECTION 4

Installation of Siding Board Direct to Ceiling Joist

#### SECTION 5

Direct on Ceiling Joist Multi-Board Soffit and Ceiling Application

#### SECTION 6

Installation of Siding Board into Resysta Runner Under Substructure Plywood

#### SECTION 7

Substructure Plywood Joist Multi-Board Soffit and Ceiling Applications

#### SECTION 8

Board Termination Trim

#### SECTION 9

Pinning Board

#### SECTION 10

Prime and Stain System

### III. Safety Warning

# I. INTRODUCTION

Resysta is an extremely durable, timber look-alike, decking material. It is resistant to damage from the sun, rain, frost and even salt water. Unlike wood, it requires minimal maintenance and is highly resistant to pests, mold and cracks. Unlike other composite materials, it closely resembles the look and feel of natural wood, with a smooth surface finish. Resysta meets most of the future environmentally sustainable material requirements concerning recycled and fully recyclable materials. Resysta is used for its architectural aesthetic, and not for structural support.

## SECTION 1 - Material Components

A combination of these three basic raw materials makes up the simple components that create Resysta. This innovative material offers designers and architects new creative horizons to utilize its compelling and unique appearance.

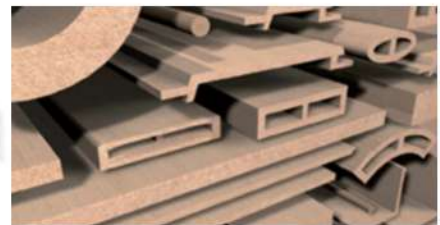

Approx. 60% RICE HUSK + Approx. 22% COMMON SALT + Approx. 18% MINERAL OIL = RESYSTA



OVERVIEW OF PARTS

## SECTION 2 - Basics

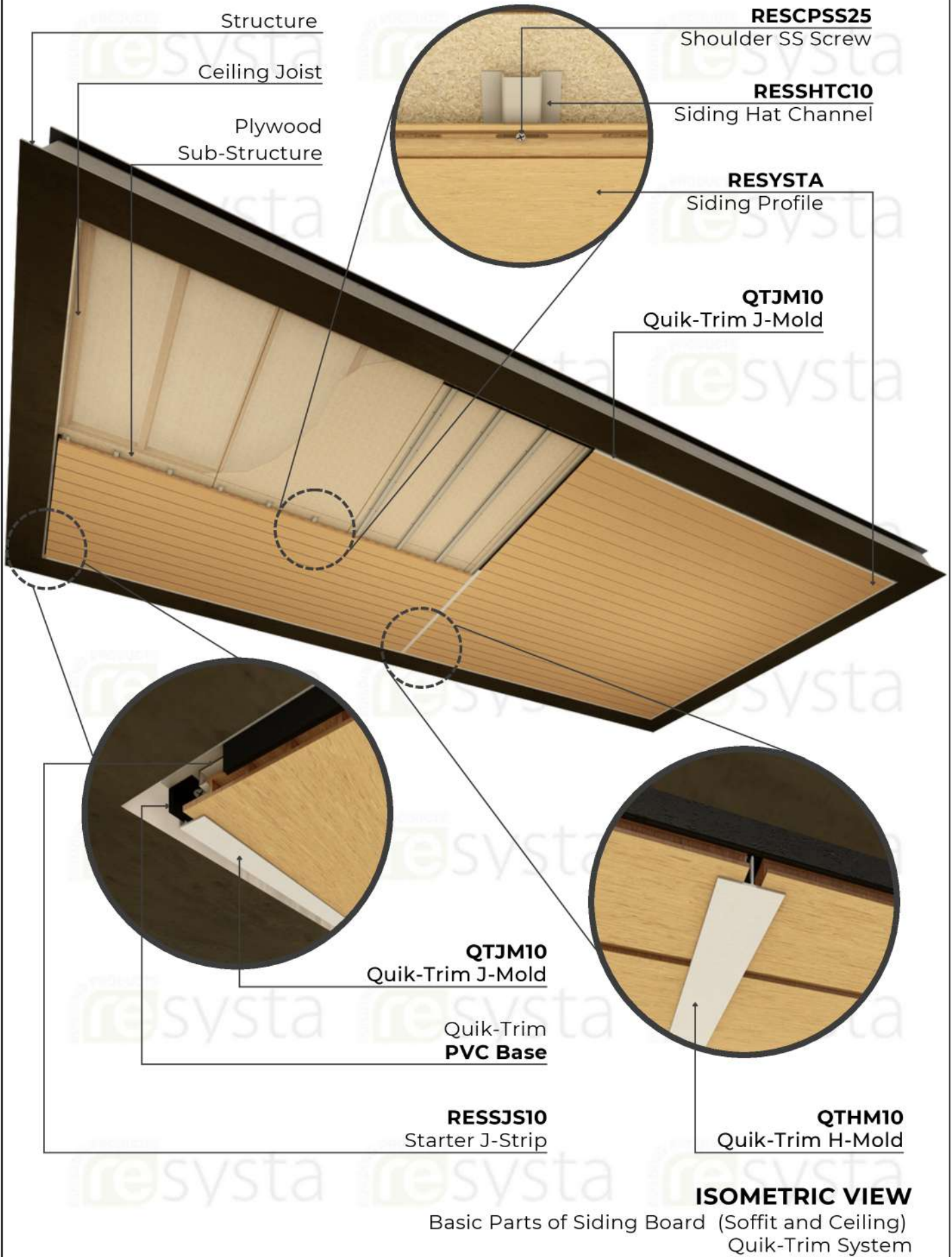

## SECTION 3 - Scope of Delivery

NO.	PRODUCT NAME AND SPECIFICATION	ISOMETRIC VIEW	SECTION VIEW
1	<b>RESCPH120412</b> 1/2" x 4" x 12' Hollow Siding Profile		
2	<b>RESCPH120612</b> 1/2" X 6" X 12' Hollow Siding Profile		
3	<b>RESSHTC10</b> 3/4" X 1 1/2" Siding Hat Channel Mill Finish		
4	<b>RESSHTC10P</b> 3/4" X 1 1/2" Siding Hat Channel Punched Mill Finish		
5	<b>QTWJM10</b> 1" x 1-37/64" Quik-Trim Windows J-Mold with Quik-Trim PVC Base		
6	<b>QTOC10</b> 1" x 1" Quik-Trim Outside Corner with Outside Corner Quik-Trim PVC Base		

NO.	PRODUCT NAME AND SPECIFICATION	ISOMETRIC VIEW	SECTION VIEW
-----	--------------------------------	----------------	--------------

7 **QTIC10**  
 1-37/64" x 1-37/64" Quik-Trim  
 Inside Corner  
 with Quik-Trim PVC Base



8 **QTHM10**  
 1-37/64" Quik-Trim  
 H-Mold  
 with Quik-Trim PVC Base



9 **QTJM10**  
 1" x 25/32" Quik-Trim  
 J-Mold  
 with Quik-Trim PVC Base



10 **RESSJS10**  
 Starter J-Strip



11 **RESCPS25**  
 1" TEC Shoulder Stainless  
 Steel Screw



Table 1.1 "Scope of Delivery"

**NOTE: 12" Siding can be used but need 12" on center attachment.**



**RESCPH011208**  
 11" x 12" x 8'  
 Hollow Siding Profile

**NOTE:**

To view a complete list of products, please refer to our Resysta brochure or visit our website [www.resystausa.com](http://www.resystausa.com).

## **IMPORTANT: Five Major Bullet Points You Must Follow for a Successful Resysta Siding Installation**

- Screw Placement
- Room for Expansion and Contraction
- Hard Fastening of each Plank
- Top to Bottom Ventilation
- Span over 16" between supports, 3 hat channels are required

### **Note:**

Proper planning of the siding board layout is essential for ease of installation of siding boards and siding components. Thoroughly read the following siding assembly instructions and obtain all necessary building permits prior to starting your installation. Decide finishing and trimming options prior to starting the project to ensure the siding finishing detail is uniform for all sides of the building. Installation is the sole responsibility of the installer. Resysta Company assumes no responsibility whatsoever with respect to the installation. The information contained herein is provided for guidance purposes only and should not be relied upon as an absolute representation by Resysta.

### **Packed finished material must be kept dry.**



When packed, finished Resysta products are exposed to moisture, it can develop mold/mildew on the board surfaces if left packed/bundled..

If packed material is exposed to moisture, open immediately and spread material to allow surfaces to dry.

This condition only applies to packed material. Finished Resysta products installed in exterior applications will not exhibit this issue.

### **Safety Tips:**

1. Always check for power, gas, and water lines before installing.
2. Always wear safety glasses when operating power equipment.

### **Assembly Tips:**

1. Battens should be flat and level with each other. Siding will follow the contour of the wall.
2. Resysta siding system is not a rainscreen or waterproof system. Resysta siding board is a watershed system.
3. Proper wall preparation according to local building codes and wall covering manufacturer's recommendations should be adhered to. This includes but is not limited to flashing all openings.
4. All holes should be predrilled and installation holes should be slotted.
5. Only use construction fastening material and hardware suitable for outdoor use (e.g. stainless steel screws). Recommended is the use of RESCPSS25 shoulder screw.
6. Always consider the linear expansion of Resysta, which is dependent on the temperature but not the air humidity. See Table 1.2 "Resysta Expansion" for more information.
7. Cut-off pieces and/or abrasive dust must be disposed of separately. Please comply with the regulations of your competent waste management. You may under no circumstances burn Resysta material.
8. Cutting to length should be carried out at consistent material temperature. Therefore, the material should be stored in the shade or in areas where it is not exposed to direct sunlight. The material can warm up considerably in the sun, leading to an increased change in length. In the case of more distinct fluctuations in material temperature, cutting to length may have to be adapted accordingly.
9. Please store Resysta products flat on a level surface.

## Code Compliant Batten Spacing

Part Number	Part Description	Batten Span (in)	Minimum Steel Gage Size
RESCPH120612	Siding Board Flat 1/2" x 6" (0.530" x 6")	16"	18
RESCPH120412	Siding Board Flat 1/2" x 4" (0.530" x 4")	16"	18

Table 1.2 "Batten Spacing Requirements"

### Recommendation for Batten Spacing

If the siding is being installed in a hot southern location and will be exposed to direct sunlight for the majority of each day and/or the siding will be stained a dark color, the batten spacing is suggested be reduced to 8" or 12" center-to-center for all siding profiles.

### Expansion / Contraction of Siding

Resysta Expansion – Contraction Guide	
Profile Length	12 ft
Expansion / Contraction amount (approx.. 0.3% over 90°F variation in temperature)	7/16" (0.432")

Table 1.4 "Resysta Expansion"

Ensure a steady material temperature when cutting the boards to size, i.e. the cutting has to be done under constant conditions, e.g. inside or in shade.

Always consider linear expansion of Resysta profiles during the installation of siding products. If temperatures fluctuate during the installation, the gaps placed between the ends of the boards and a corner, window, or door must change with the temperature. Use the guide above to gap boards during installation.

Resysta Siding Profile Board Gap Guide					
Temperature at Installation	Trim Gap of Siding Board				H-Channel Gap
	Below 30° F	60°F	90°F	120°F	
Amount for Siding Profile Length of 12 ft.	7/16"	5/16"	3/16"	0"	1/4"

Table 1.4 "Resysta Expansion"

Ensure a steady material temperature when cutting the boards to size, i.e. the cutting has to be done under constant conditions, e.g. inside or in shade.

**Expansion – Contraction Tips:**

**1)Control Piece**

at the start of the day cut a length of board that is desired to be installed and keep this board in the same area as the cutting and storage of the remaining boards. This board will be a "Control Piece" to reference when cutting other boards to be installed. Throughout the day the "Control Piece" can be referenced and the saw cuts adjusted accordingly as the boards expand and/or contract. The heat from the sun will cause Resysta boards to expand so if the material is stored in the shade keep the "Control Piece" in the shade as well.

**Example:**

If 12ft boards are being installed put aside one 12ft board at the start of the day. Reference these boards throughout the day and adjust the cutting of the other boards to match.

**2)Control Gap**

at the start of the installation place the board gap according to Table 1.4 and mark the first gap made. This gap will be a "Control Gap" to reference when gapping the remaining boards to be installed. Throughout the installation reference back to this "Control Gap" to match the other gaps being installed. This will ensure that all the gaps installed are the same.

## II. INSTALLATION - PROCEDURE

### SECTION 1 - Review the Reflected Ceiling Plan

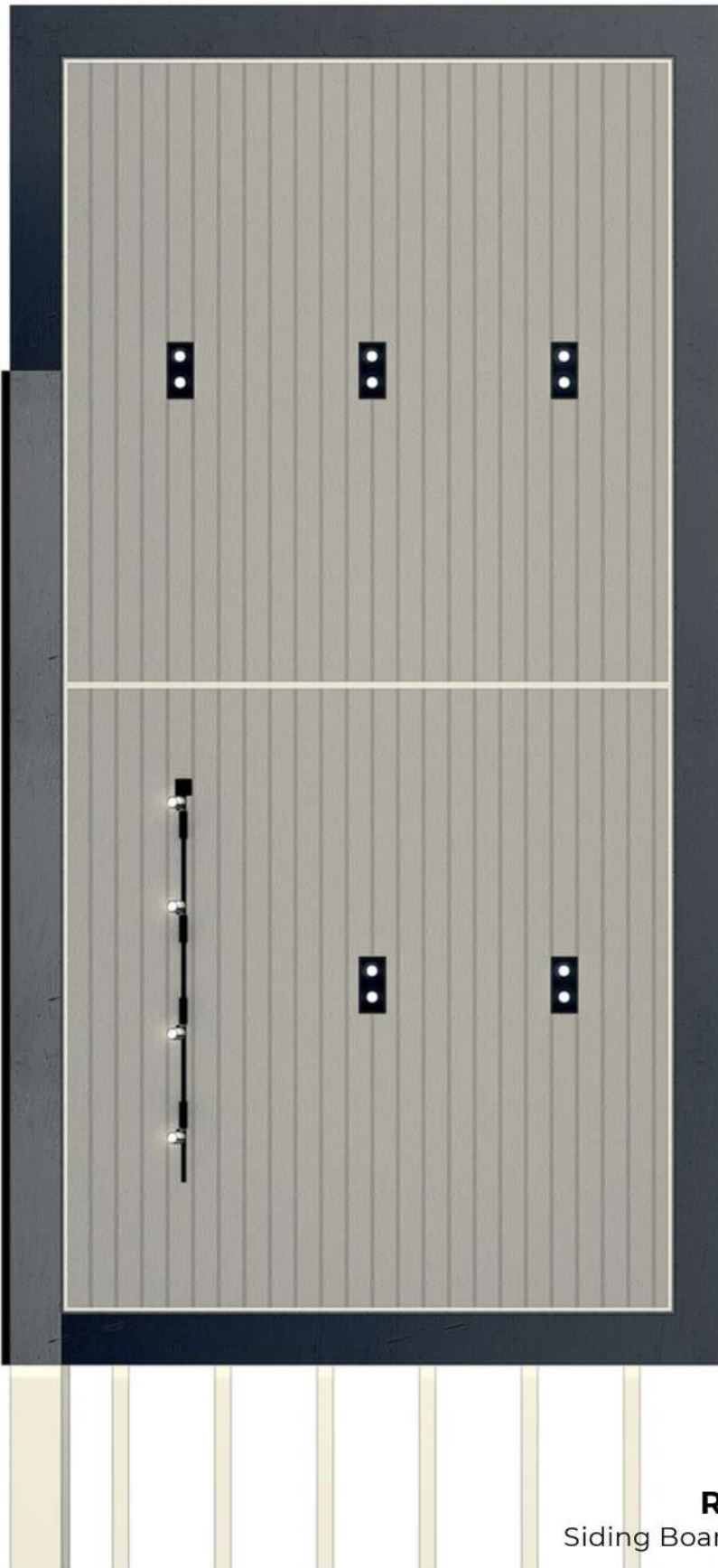

Before starting the installation, it is advised to carefully study the Reflected Ceiling Plan (RCP).

*The Reflected Ceiling Plan (RCP) is an architectural drawing, showing the placement of the lighting, sprinklers, smoke detectors, and other mechanical or electrical components.*

By studying the RCP, you can assess the affected areas where the siding profiles on the soffit and ceiling are to be installed.

#### **REFLECTED CEILING PLAN**

Siding Board on Soffit and Ceiling Lay-out  
Quik-Trim System

## SECTION 2 - Batten Substructure

### General Notes on Batten Substructure

Resysta siding boards on the soffit and ceiling can be installed in longitudinal or transverse applications and the batten substructure should be planned to accommodate how the siding boards will be installed.

Note that there are two substructures that Resysta battens can be installed whether:

- (1) *Substructure 1*. Direct on Ceiling joist; or
- (2) *Substructure 2*. Resysta Runners under Substructure Plywood.

### Substructure 1

Direct on Ceiling Joist



**ISOMETRIC VIEW**

Substructure 1

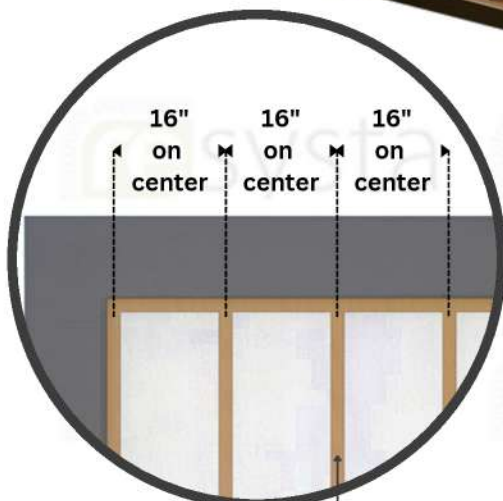

Ceiling Joists

**NOTE:**

Siding board can be installed direct into the ceiling joist considering that the spacing of the joist is **16" or less**.



**PLAN**

Substructure 1

## Substructure 2

Resysta Runners under Substructure Plywood

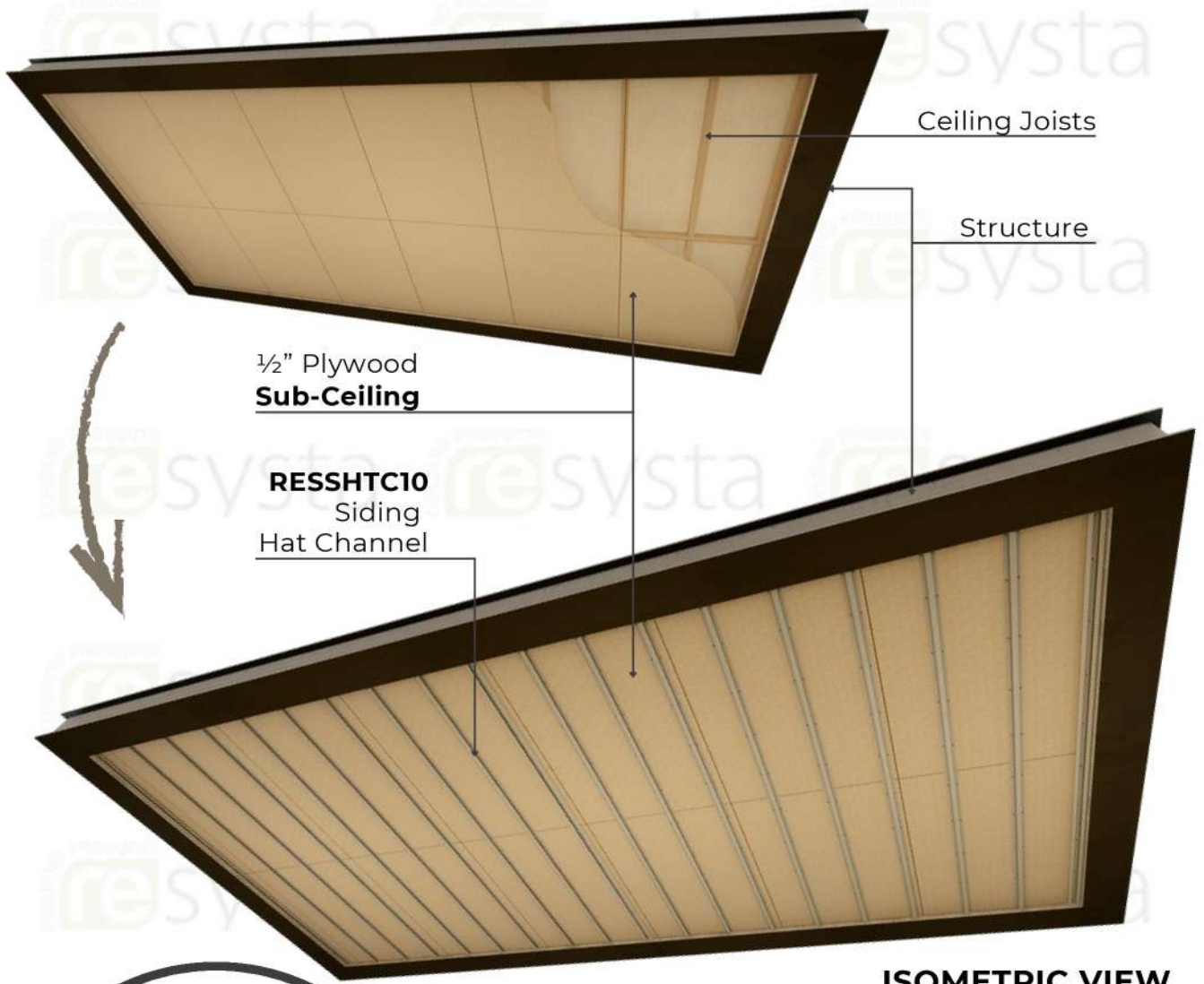

### ISOMETRIC VIEW

Substructure 2

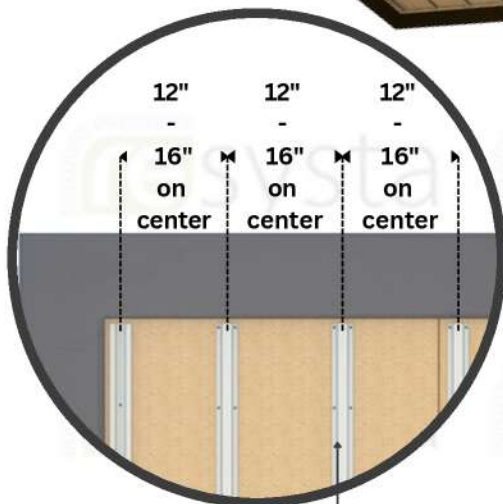

Siding Hat Channels

#### NOTE:

Install the aluminum hat channel runners under the 1/2" plywood sub ceiling support with **12" to 16"** on center runner spacing before installing the siding board.

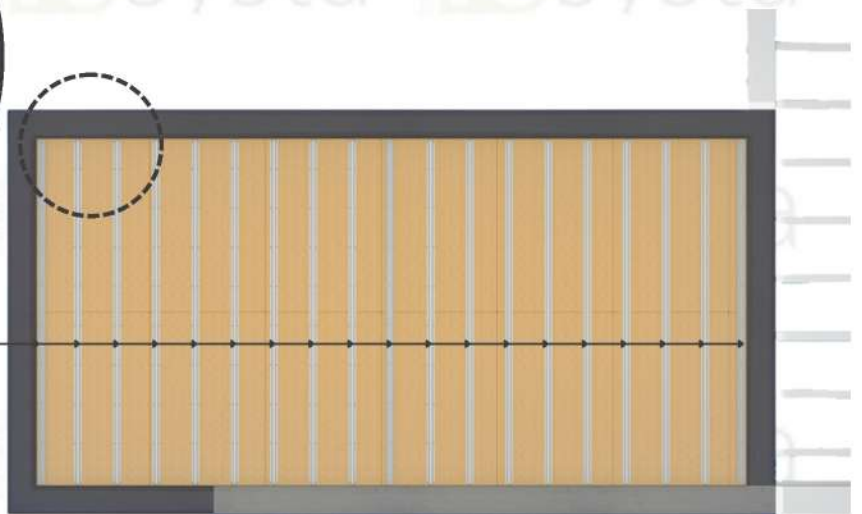

Substructure 2

## **Resysta Aluminum Batten Substructure**

Install the battens and secure them to the frame substructure in compliance with local building codes. Ensure that the installed battens do not exceed the “Batten Spacing Requirements” of Table 1.2. On walls where two siding boards will be used end-to-end, a minimum of two battens must be used to accommodate the fastening of the siding boards and any trim pieces desired to the batten substructure where the boards meet. Prior to installing the Resysta siding boards, ensure that the batten installation provides a minimum  $\frac{3}{4}$ ” air gap behind the siding boards and there is sufficient support for all siding boards and trim accessories. This is often achieved through the installation of battens with a minimum thickness of  $\frac{3}{4}$ ”

Battens should be installed on top of a code-compliant sheathing with fasteners and fastener spacing sufficient to accommodate all loads imposed upon it by the Resysta siding board, trim components, and any other accessories attached to the battens. Resysta siding boards must be attached to aluminum battens with Resysta Shoulder stainless steel screws (RESCPSS25 Screw) taking care to not penetrate the weather barrier. If the weather barrier is going to be penetrated reference the weather barrier manufacturer’s recommendations. Notes on Resysta Shoulder Screw RESCPSS25.

## **SECTION 3 - Trim and Accessory Options**

Aluminum Siding Trim systems made for Resysta siding boards are recommended for covering the ends and gaps of siding boards. Suggested supply includes, but is not limited to: Quik-Trim Outside Corner Trim, Quik-Trim Inside Corner Trim, Starter J-Strip (to start siding boards), Quik-Trim H-Channel Trim (to cover wall gaps), Quik-Trim J-Channel Trim (used for siding board termination). Aluminum Quik-Trim Siding Trims are standard aluminum alloy 6063 T5 and have a .050” nominal wall thickness. Aluminum Siding Trims come in 10’ lengths and shall have a standard Mill Finish for field priming and painting unless otherwise specified.

### **Aluminum Quik-Trim Siding – General Installation Guidelines**

Aluminum Quik-Trim Siding Trim must be cut with a 150-tooth carbide-tip blade for nonferrous metal. Blade Lubricant must be applied to the blade before each cut and the lubricant should be cleaned from the trim prior to installation. None of the Siding Trim should be installed horizontally unless weep holes are drilled at 8” intervals to allow for moisture to escape from behind the face flange. Exceptions to this are 1) a Siding Starter J-Strip installed in any direction and 2) a Quik-Trim Siding J-Channel Trim when it is installed horizontally with its face flange pointing down.

### **Resysta Aluminum Quik-Trim Siding – Aluminum Batten Installation Guidelines**

When using metal battens, either steel or aluminum, it is recommended to use the shoulder SS Screw RESCPSS25 which can be driven through the aluminum siding trim and into the metal batten. The trim should be fastened 16” on the center for either horizontal or vertical installations. If the batten substructure spacing is reduced for the siding boards the trim should be fastened at the same interval as the siding. Be aware of fastener placement for the siding trim so as to not hinder the installation of the Resysta siding boards.

## SECTION 4 - Installation of Siding Board Direct into the Ceiling Joist

### Substructure 1

Direct on Ceiling Joist

#### STEP 4.1

Pre apply all finishing trim accessories such as trim around corners, skylights, and other pre plan layout ceiling components and following the manufacture's recommendations. Ensure that all trim is level and square.



## STEP 4.2

Attach the Starter J-Strip directly to the ceiling joist substructure. The Aluminum Starter Strip is required to install the Resysta siding board on the soffit. The Resysta siding boards on the soffit will have a space of  $\frac{1}{2}$ " from the Quik-Trim J-Mold to the wall therefore the starter strip should be attached  $1\frac{3}{4}$ " from the wall in accordance with the Reflected Ceiling Plan (RCP).



### STEP 4.3

The Quik-Trim PVC base should be installed on end ceiling joists and on both ends of all the ceiling joists, by screwing on the PVC base on its groove.

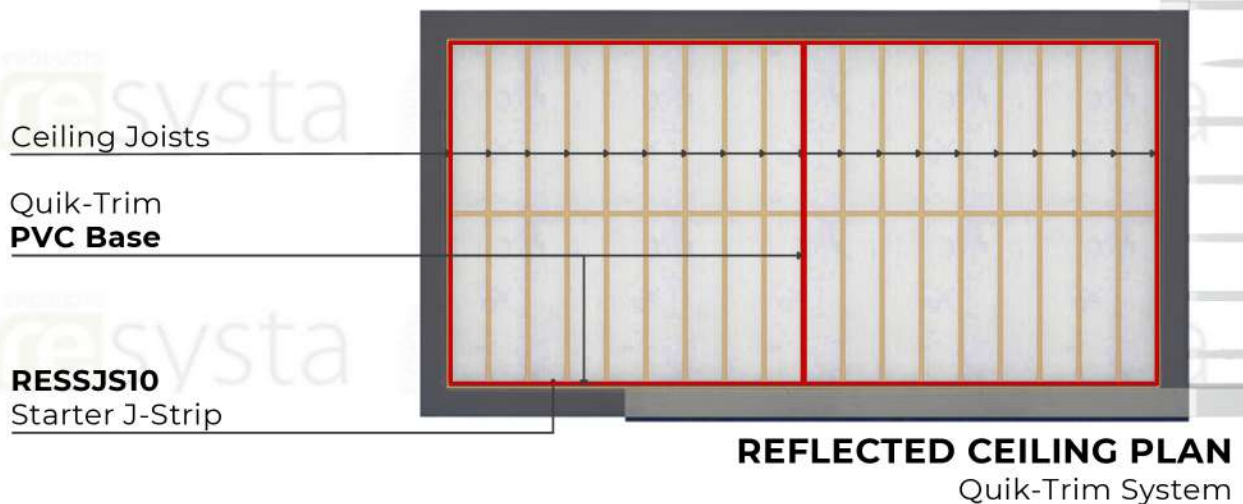

## STEP 4.4

Hook the groove end of the first siding board into the Starter J Strip.



### DETAIL 1

Slide down the first Resysta Siding board into Starter J-Strip.



### DETAIL 2

Hook the groove end of the first Resysta Siding board into the Starter J-Strip with SS screw.



### DETAIL 3

Push the Resysta Siding board perpendicular into the joist and screw direct to the groove.



### STEP 4.5

Install #8 Flathead 1-1/2" wood screw into all slotted holes except the center hole. DO NOT over tighten the screws. The screws should be placed in the center of the slotted hole and loose enough to allow the board to move freely from side to side to allow for expansion and contraction.

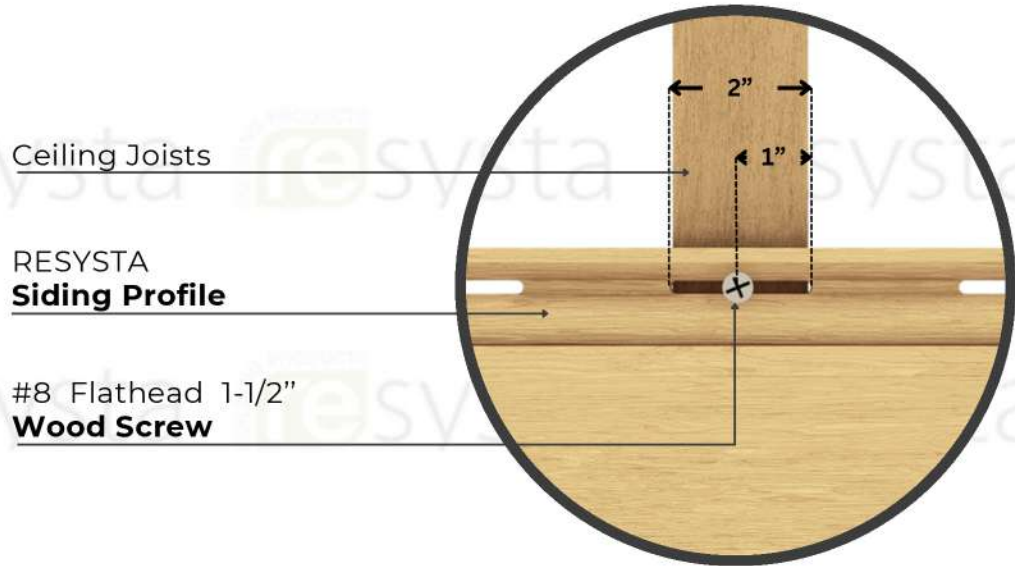

**ISOMETRIC DETAIL**

Quik-Trim System

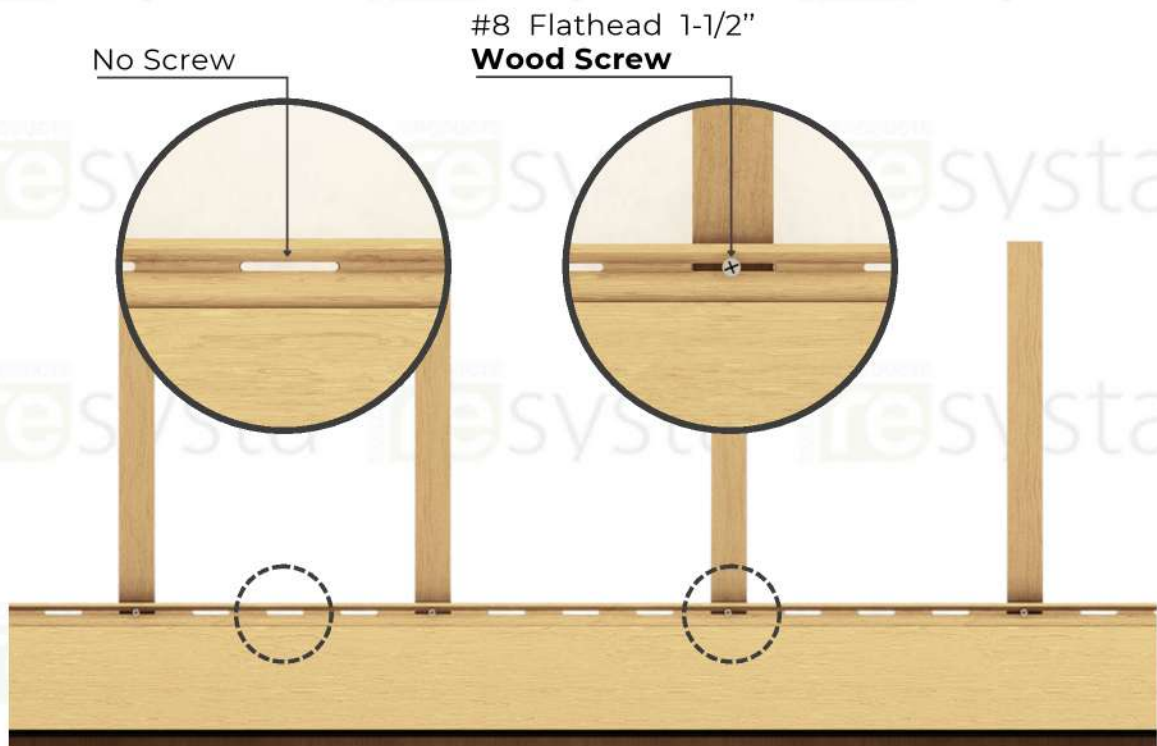

**REFLECTED CEILING PLAN**

Quik-Trim System

#### Note

If installing more than one board in width, please refer to Section 5 – Horizontal Multi Board Siding Applications

## STEP 4.6

Install the final two #8 Flathead 1-1/2" wood screw in the slotted hole in the center of the board. This will allow for expansion and contraction evenly to each side of the assembly.

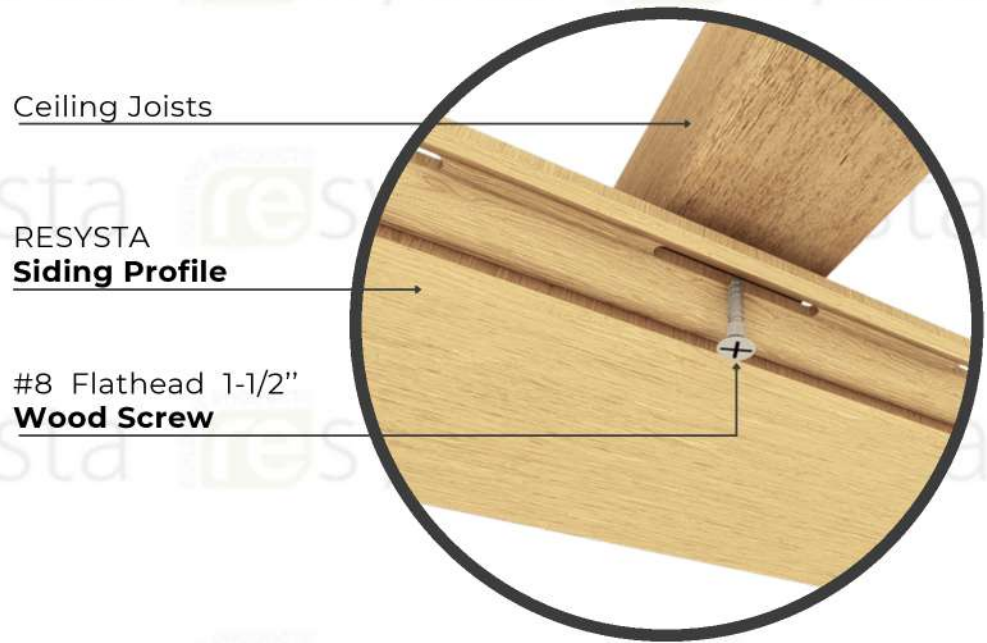

**ISOMETRIC DETAIL**  
Quik-Trim System

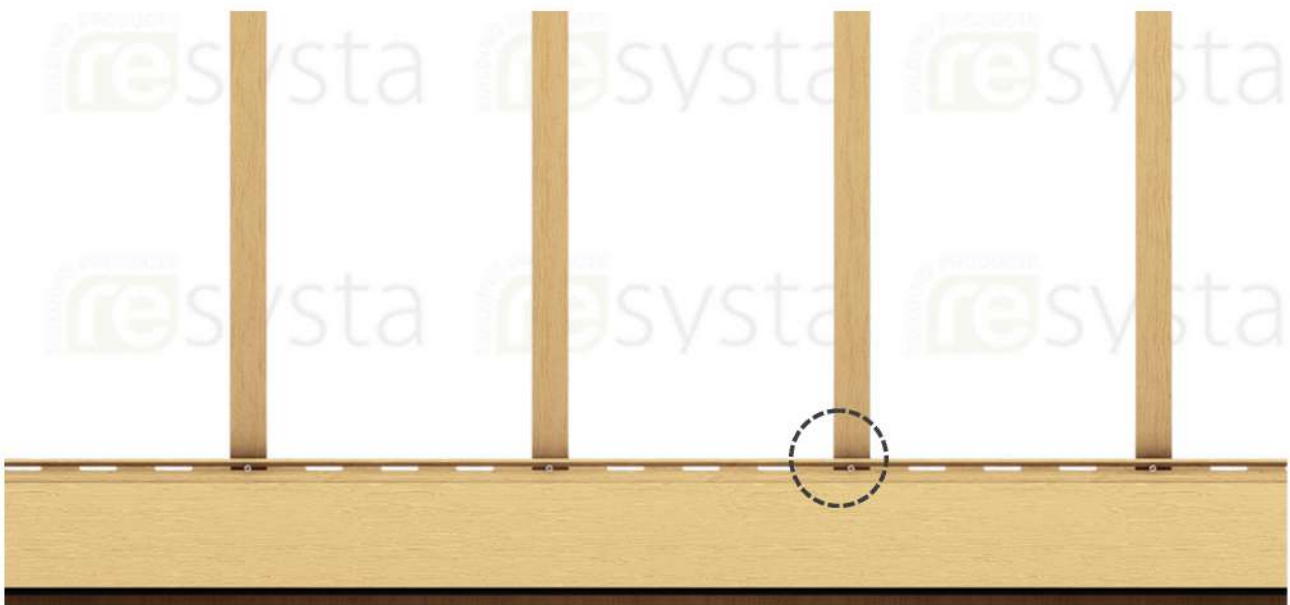

**REFLECTED CEILING PLAN**  
Quik-Trim System

## STEP 4.7

Hook the groove end of the next board onto the tongue of the installed siding board.

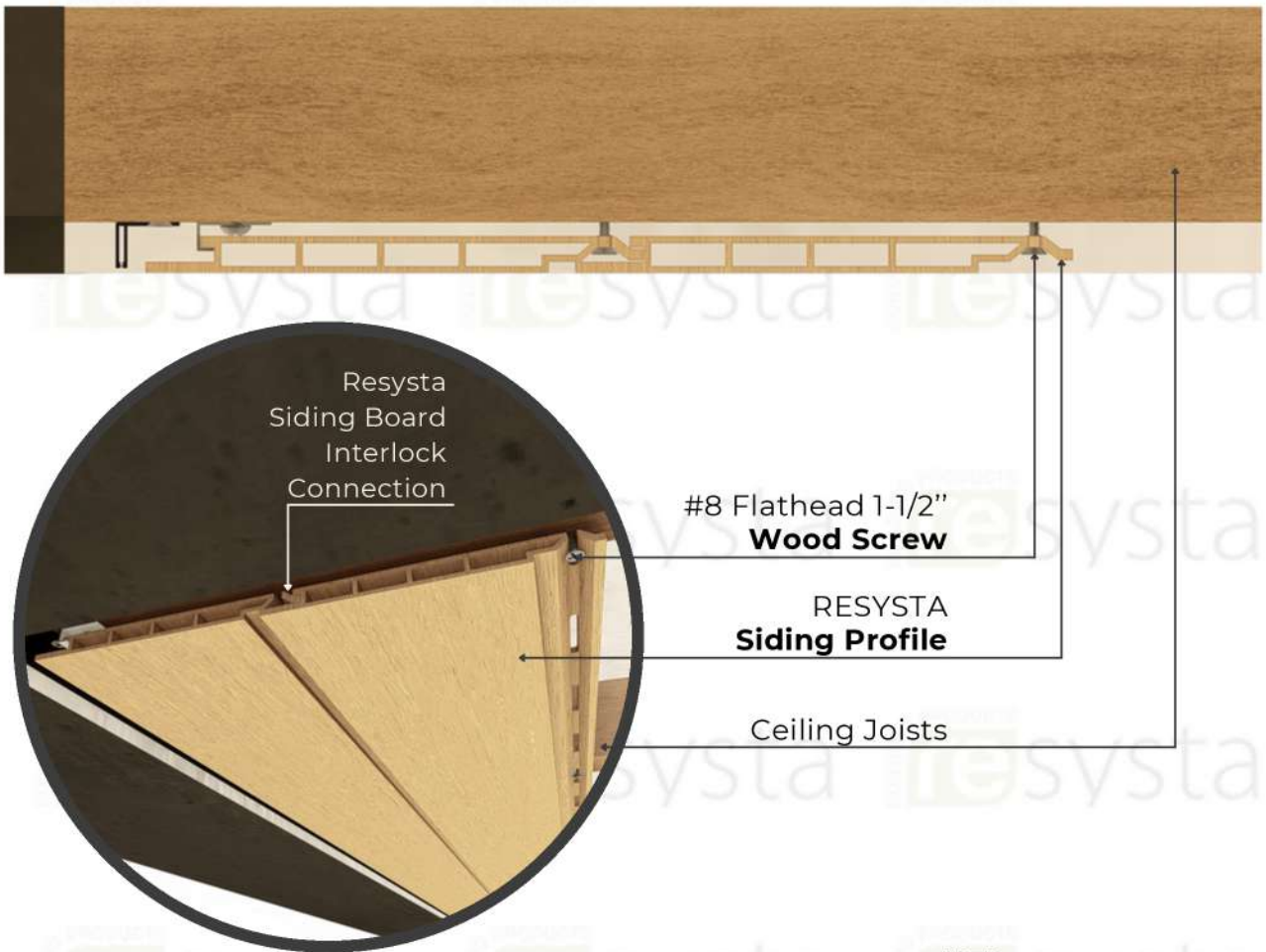

### ISOMETRIC DETAIL

Quik-Trim System

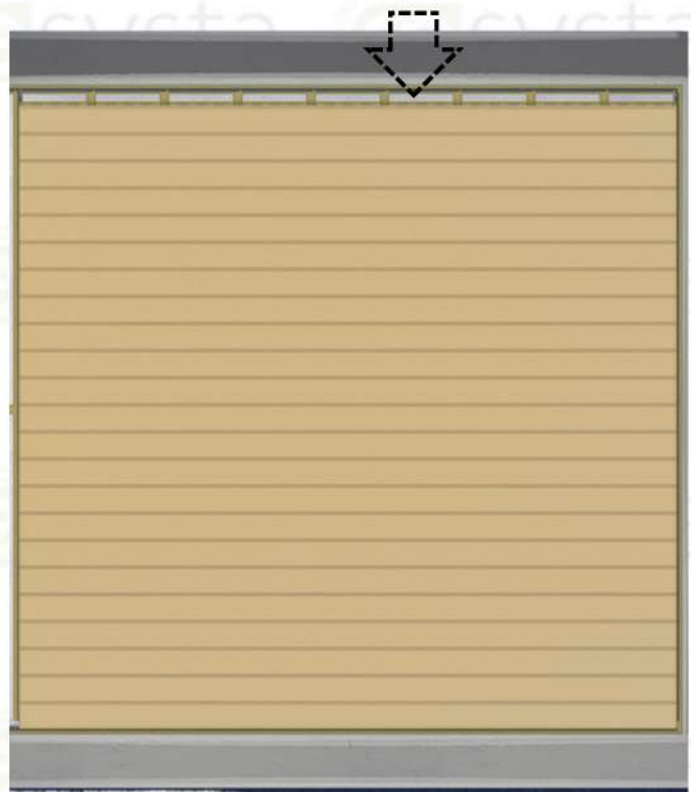

### REFLECTED CEILING PLAN

Quik-Trim System



### DETAIL

Quik-Trim System

## STEP 4.8

Continue installing siding boards as outlined in Section 3. Rip the last siding board into size to complete the siding.



### ISOMETRIC DETAIL

Quik-Trim System

### REFLECTED CEILING PLAN

Quik-Trim System

## STEP 4.9

After the installation of the last Resysta siding board, the exposed siding edges will be finished by installing the aluminum Quik-Trim. Install the J-mold into the PVC base on all the perimeter / sides of the siding installation.



# SECTION 5 - Multi-Board Soffit and Ceiling Applications Direct on Ceiling Joist

## 2 Board Wide Installation without the Aluminum Quik-Trim H-mold (24ft max width)

### STEP 5.1.1

Follow Steps 4.1, 4.2, and 4.3 from Section 4 to install the finishing trim, starter J-strip, and hook in the 1st siding board.

### STEP 5.1.2

Install #8 Flathead 1-1/2" wood screw into all slotted holes except the hole closest to the abutted joint on both siding boards. DO NOT over-tighten the screws. The screws should be placed in the center of the slotted hole and loose enough to allow the board to move freely from side to side to allow for expansion and contraction.

Quik-Trim  
PVC Base

Ceiling Joist



**REFLECTED CEILING PLAN**  
Quik-Trim System

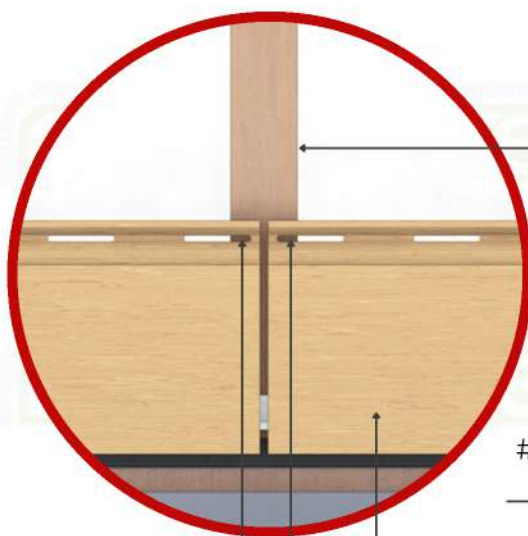

No  
Fastener

#### DETAIL

@ Board Abutment  
Quik-Trim System

Ceiling Joist

#8 Flathead 1-1/2"  
Wood Screw

RESYSTA  
Siding Profile

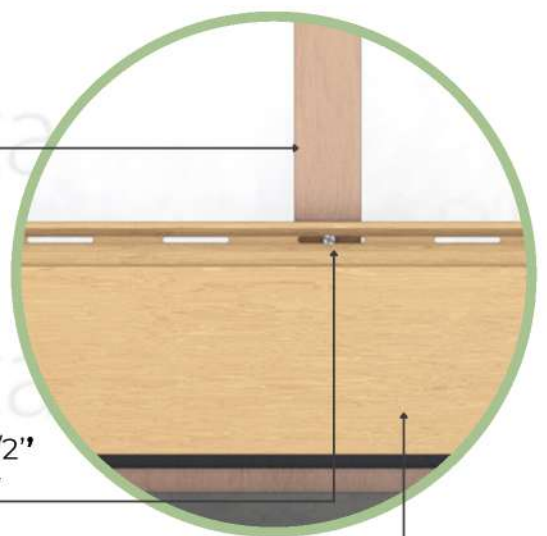

**DETAIL**  
Rest of Slotted Holes  
Quik-Trim System

### STEP 5.1.3

Install one #8 Flathead 1-1/2" wood screw in the slotted hole closest to the abutted joint on both siding boards. This will control expansion and contraction evenly to the outside of the siding boards while keeping the abutting joint snug.

Quik-Trim  
PVC Base

Ceiling Joist



### REFLECTED CEILING PLAN

Quik-Trim System

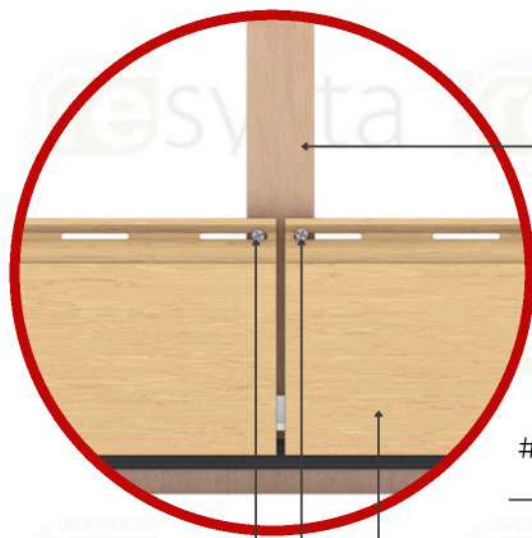

#8 Flathead 1-1/2"  
Wood Screw

### DETAIL

@ Board Abutment  
Quik-Trim System

#8 Flathead 1-1/2"  
Wood Screw

RESYSTA  
Siding Profile

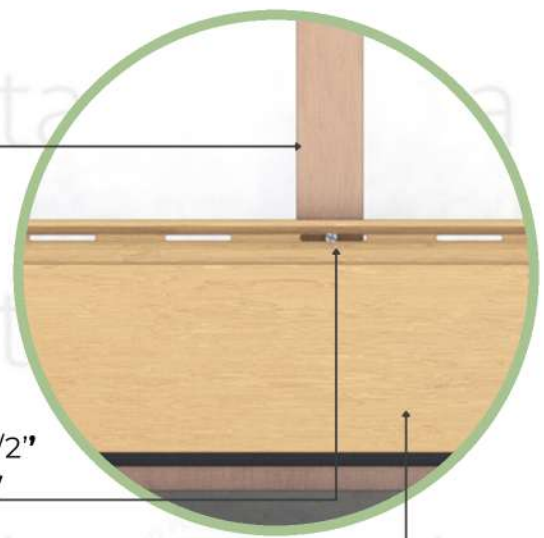

### DETAIL

Rest of Slotted Holes  
Quik-Trim System

### STEP 5.1.4

Hook the groove end of the next board onto the tongue of the installed siding board.

### STEP 5.1.5

Continue installing siding boards as outlined in Section 5: "Installation of Siding Board Direct into the Ceiling Joist without the Aluminum Quik-Trim H-mold" and follow steps 4.8 and 4.9 in Section 4 to finish the installation.

## Multi-Board Wide Installation using Continuous Aluminum Quik-Trim H-mold

### STEP 5.2.1

Follow Steps 4.1, 4.2 and 4.3 from Section 4.

### STEP 5.2.2

Install the Quik-Trim PVC base into the hat channel where the aluminum Quik-Trim H-mold will be installed.



Quik-Trim  
**PVC Base**

Ceiling Joists

**RESSJS10**  
Starter J-Strip



Quik-Trim  
PVC Base

Ceiling Joist

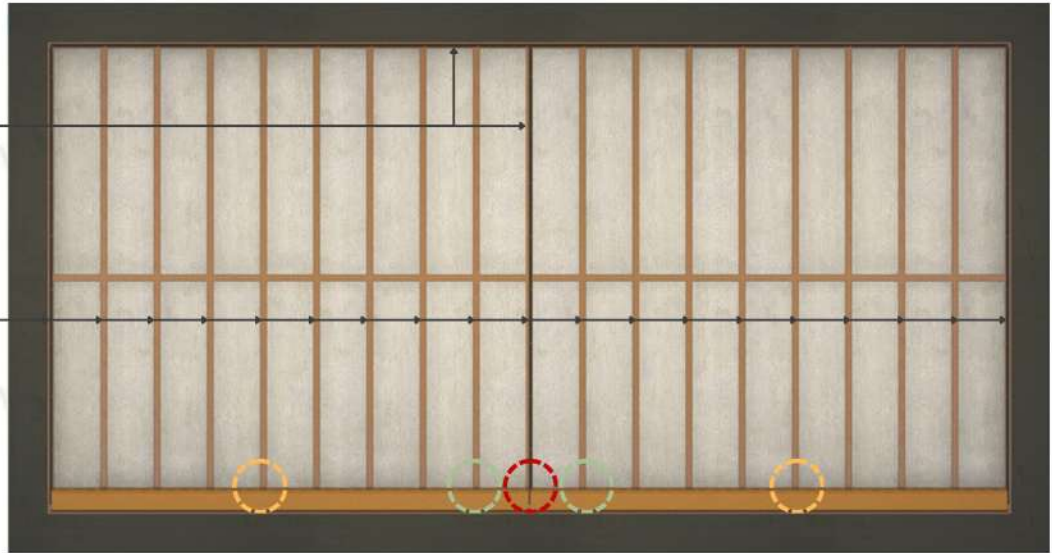

**REFLECTED CEILING PLAN**

Quik-Trim System

**STEP 5.2.3**

Follow steps 4.4, 4.5, and 4.6 of Section 4 and install RESCPSS25 screws or #8 screws into all slotted holes except the center hole. DO NOT over-tighten the screws. The screws should be placed in the center of the slotted hole and loose enough to allow the board to move freely from side to side to allow for expansion and contraction.

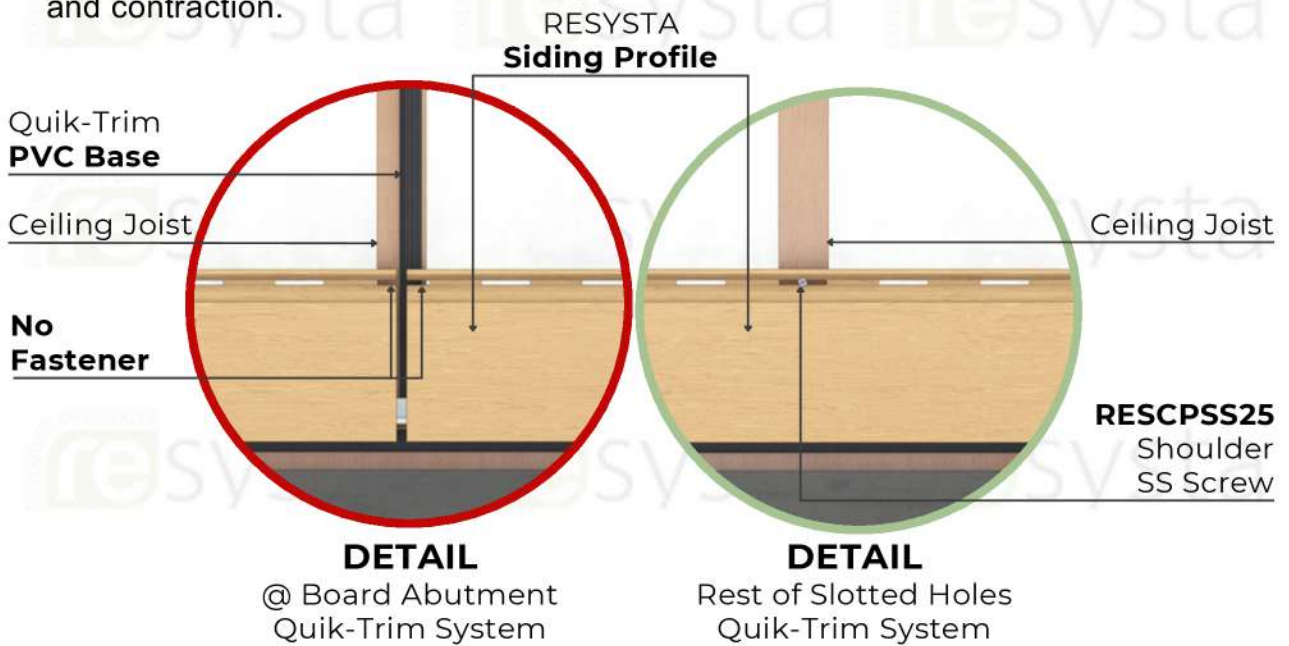

**STEP 5.2.4**

Install the final two RESCPSS25 screws closest to the ends in the slotted hole in the center of the board. This will allow for expansion and contraction evenly to each side of the assembly.

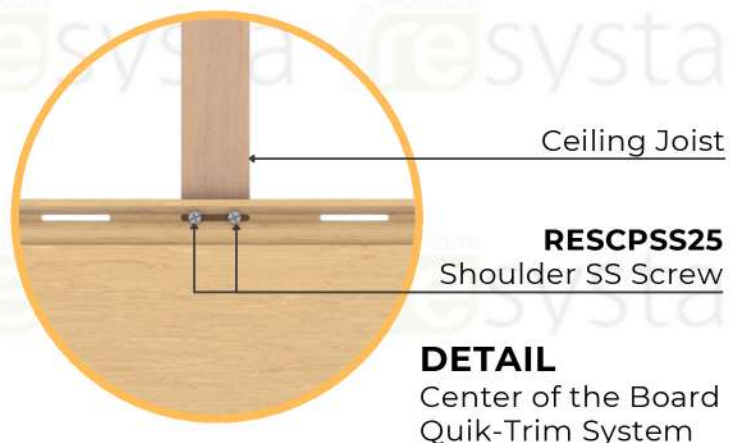

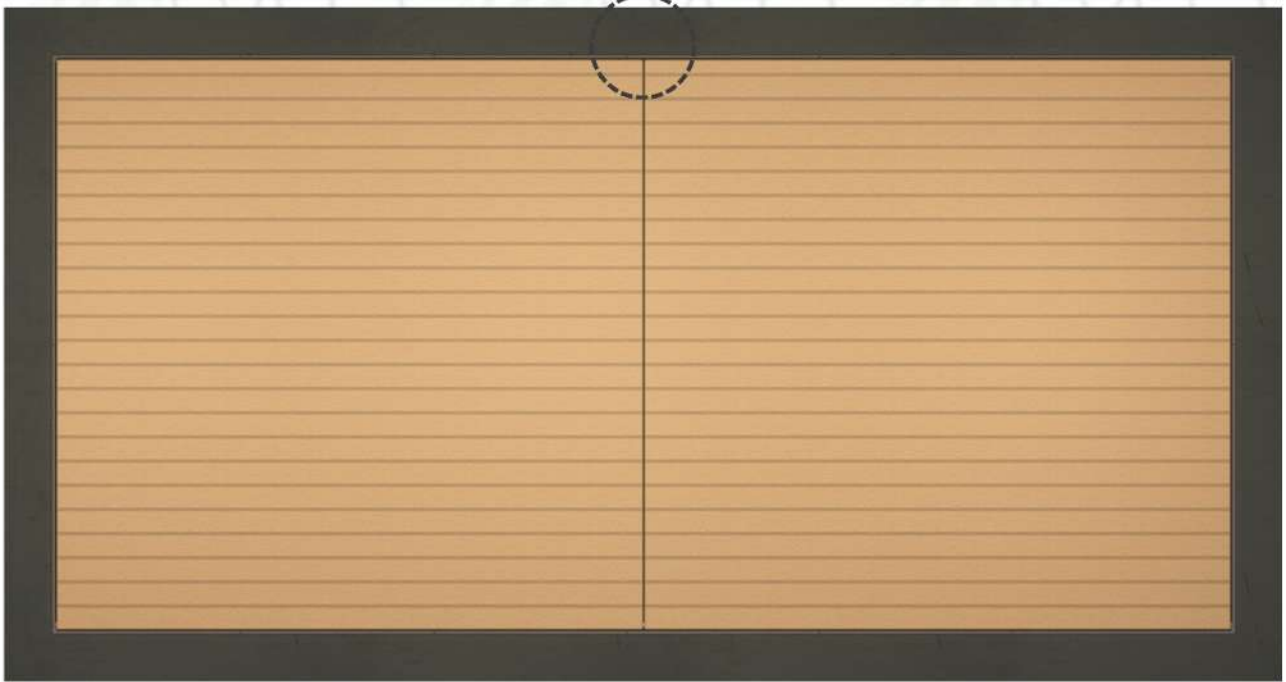

**REFLECTED CEILING PLAN**  
Quik-Trim System

Ceiling Joist

Quik-Trim  
**PVC Base**

RESYSTA  
**Siding Profile**



**DETAIL**  
Quik-Trim System

## STEP 5.2.5

After the installation of the last siding board, finally install all the aluminum trim on the PVC base to finish the installation.

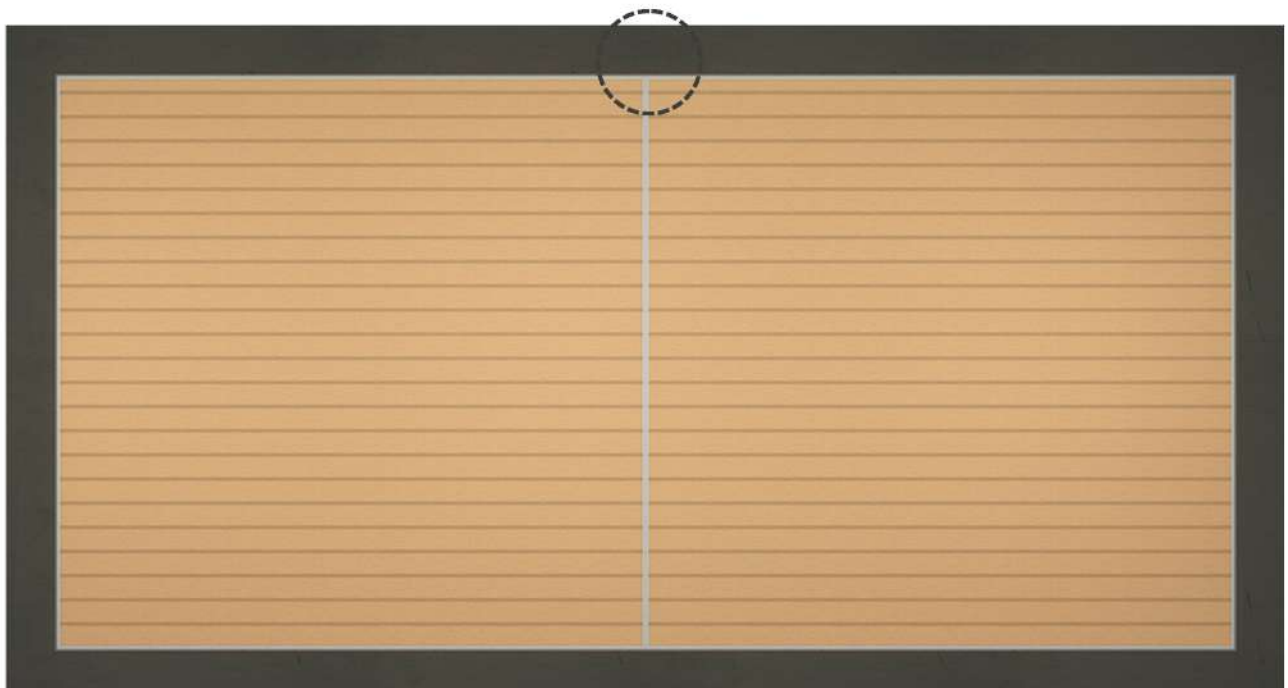
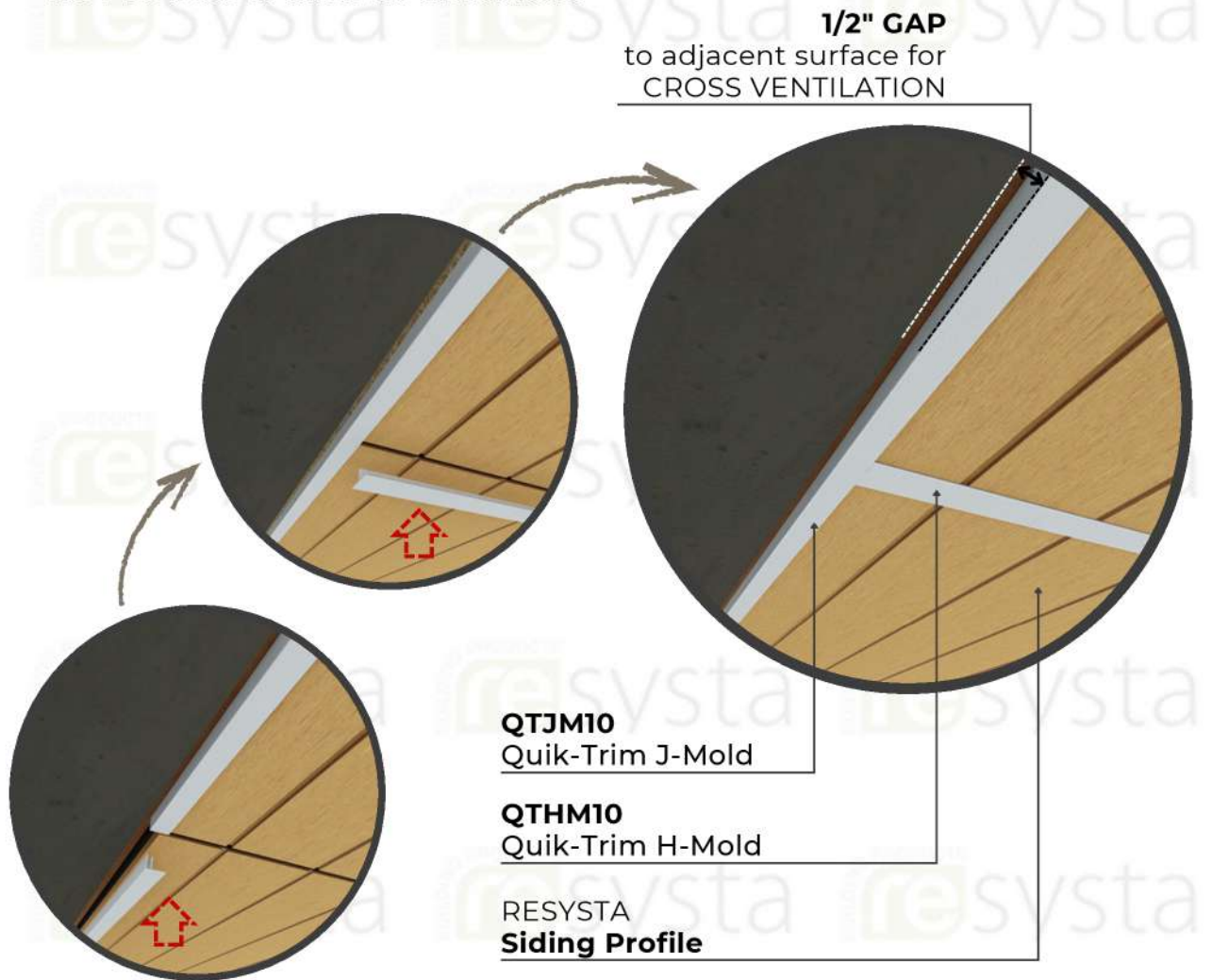

**REFLECTED CEILING PLAN**  
Quik-Trim System

# SECTION 6 - Installation of Siding Board Direct on Resysta Runners Under Substructure Plywood

## Substructure 2

Resysta Runners Under Substructure Plywood

### STEP 6.1

Install the aluminum hat channel runners under the substructure plywood, following the recommended runner spacing of 12" to 16" center to center of runners. Pre apply all finishing trim accessories such as trim after the installation of the runners around the corners, skylights, and other pre plan layout ceiling components and following the manufacture's recommendations. Ensure that all trim is level and square.

1/2" Plywood  
**Sub-Ceiling**

**RESSHTC10**  
Siding  
Hat Channel

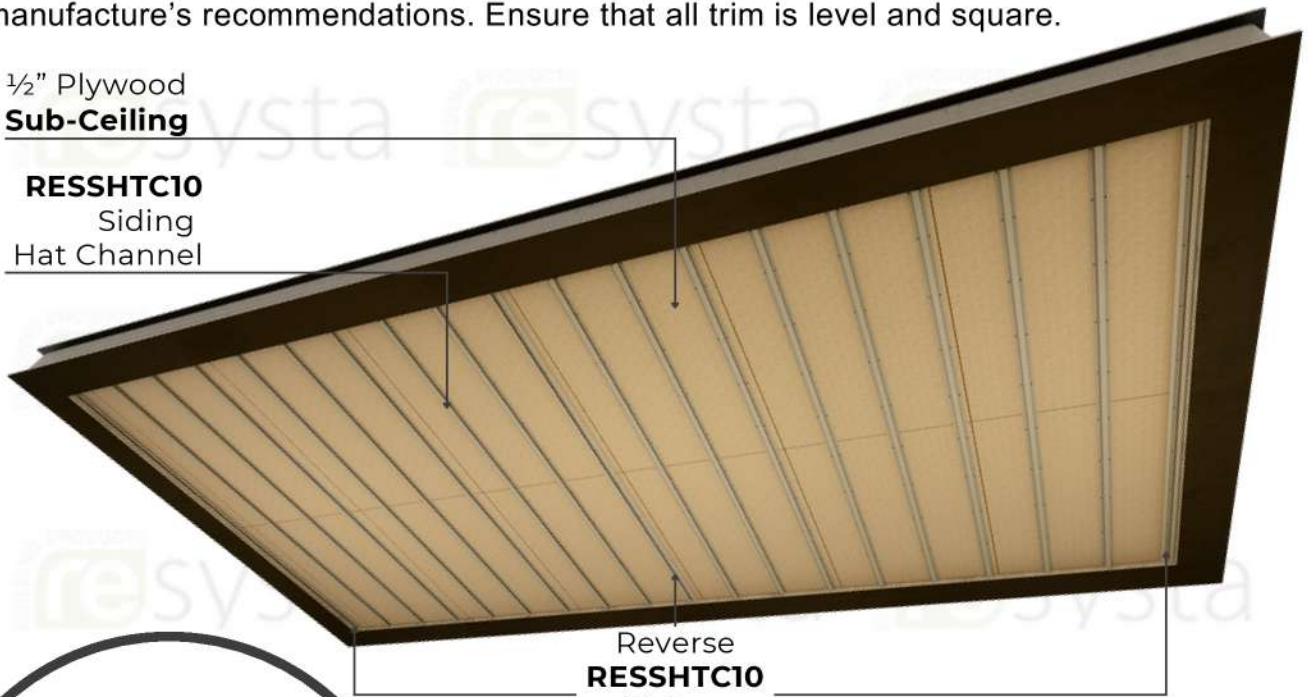

Reverse  
**RESSHTC10**  
Siding  
Hat Channel

**ISOMETRIC VIEW**  
Substructure 2

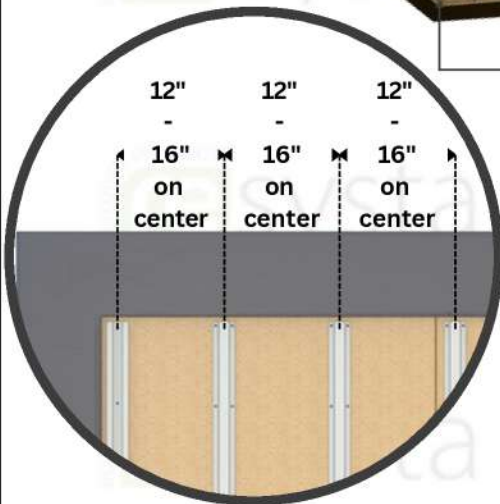

Reverse Siding Hat Channels  
Siding Hat Channels

**NOTE:**

Install the aluminum hat channel runners under the 1/2" plywood sub ceiling support with 12" to 16" on center runner spacing before installing the siding board.

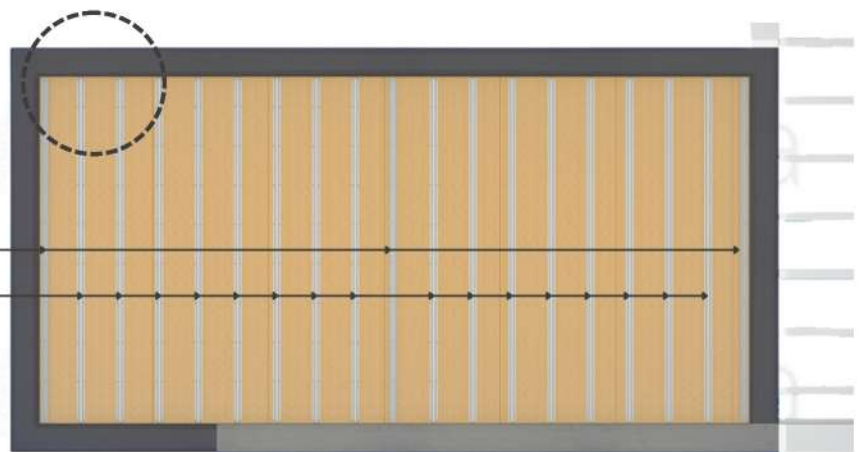

**PLAN**  
Substructure 2

## STEP 6.2

Attach the Starter J-Strip at the ends of the battens following the fastener and spacing recommendations in Section 2. The Aluminum Starter Strip is required to install the Resysta siding board on the soffit. The Resysta siding boards on the soffit will have a space of  $\frac{1}{2}$ " from the Quik-Trim J-Mold to the wall therefore the starter strip should be attached  $1 \frac{3}{4}$ " from the wall in accordance with the Reflected Ceiling Plan (RCP).

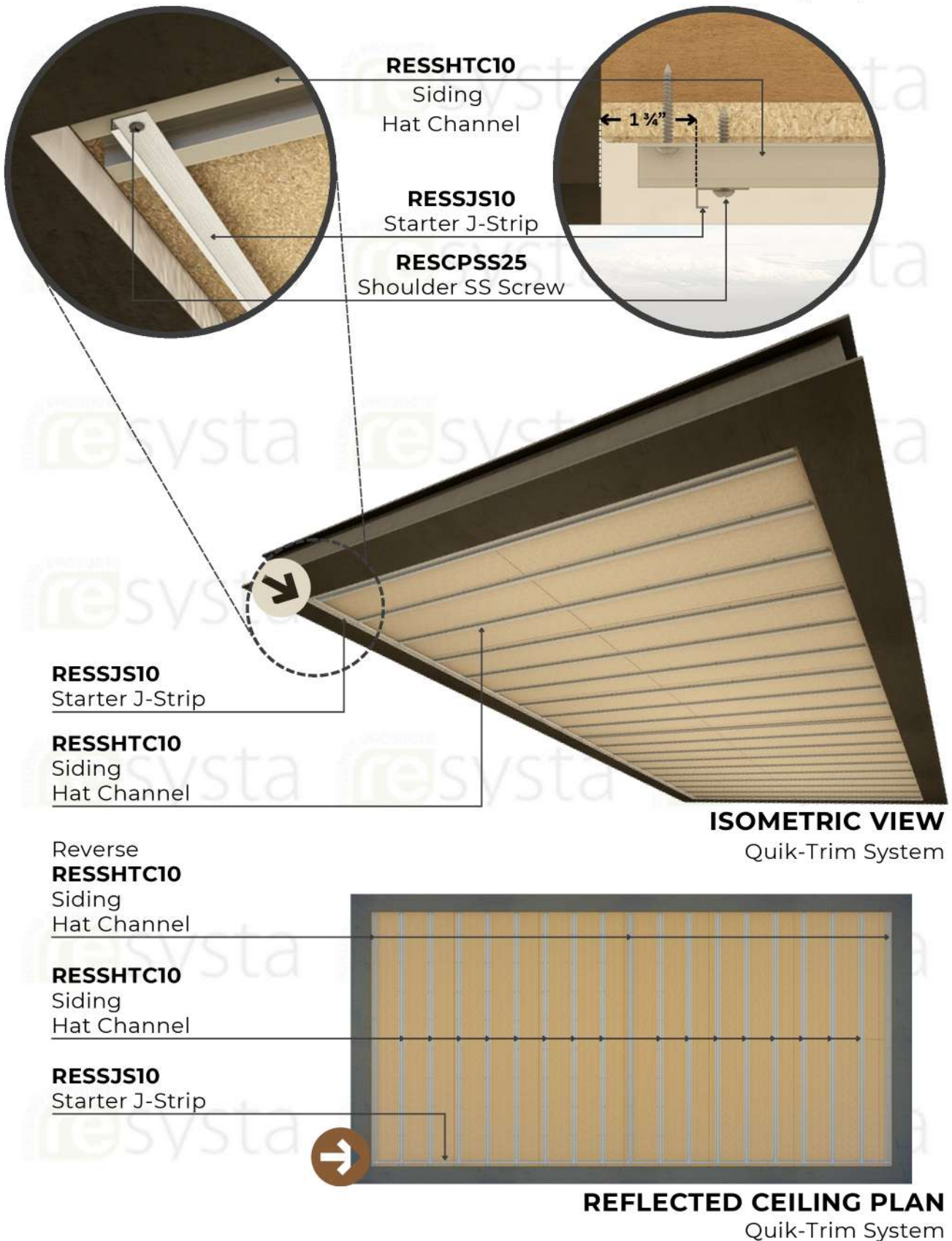

### STEP 6.3

The Quik-Trim PVC base should be installed on end ceiling joists and on both ends of all the ceiling joists, by screwing on the PVC base on its groove.

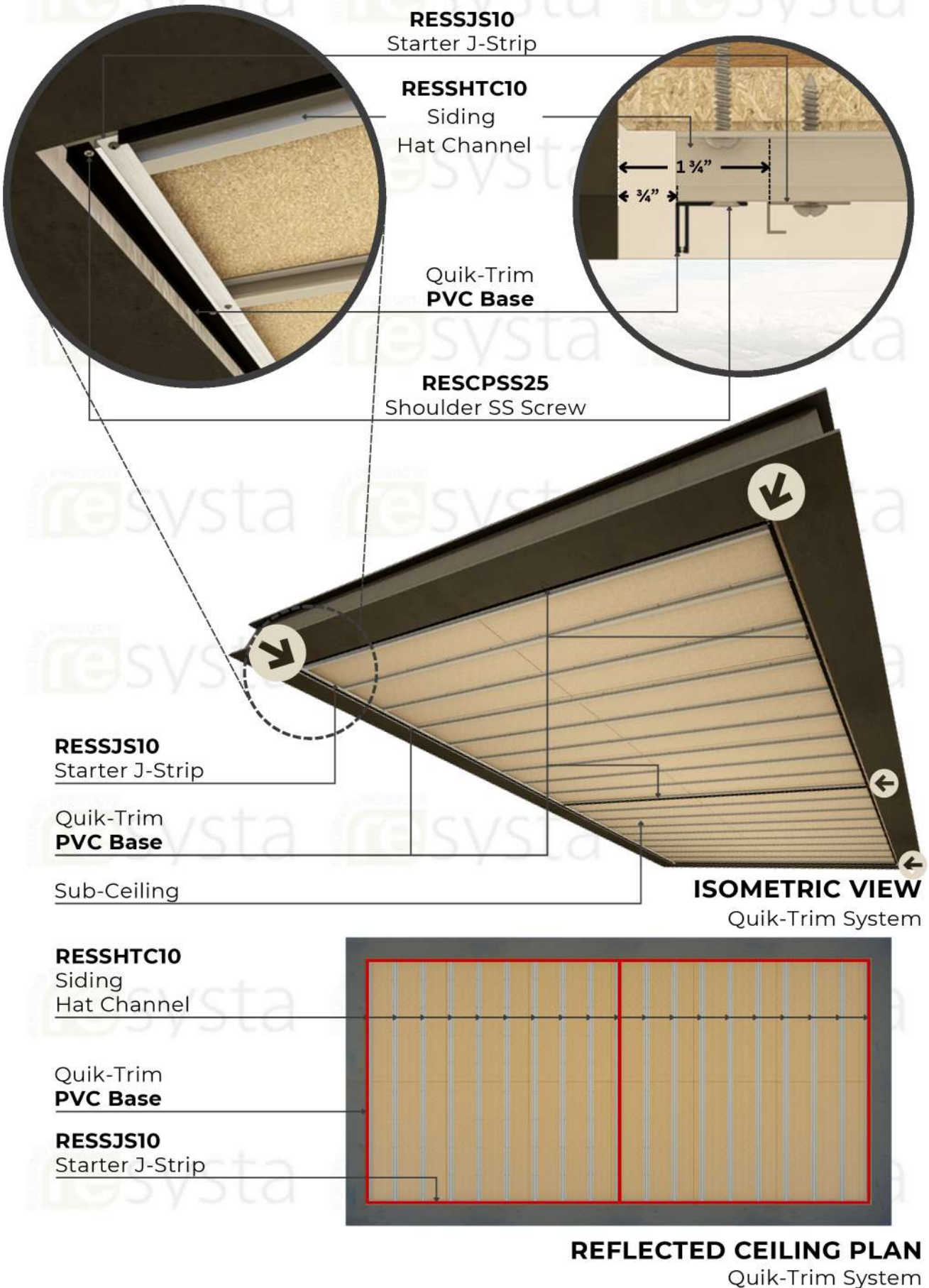

## STEP 6.4

Hook the groove end of the first siding board into the Starter J Strip.

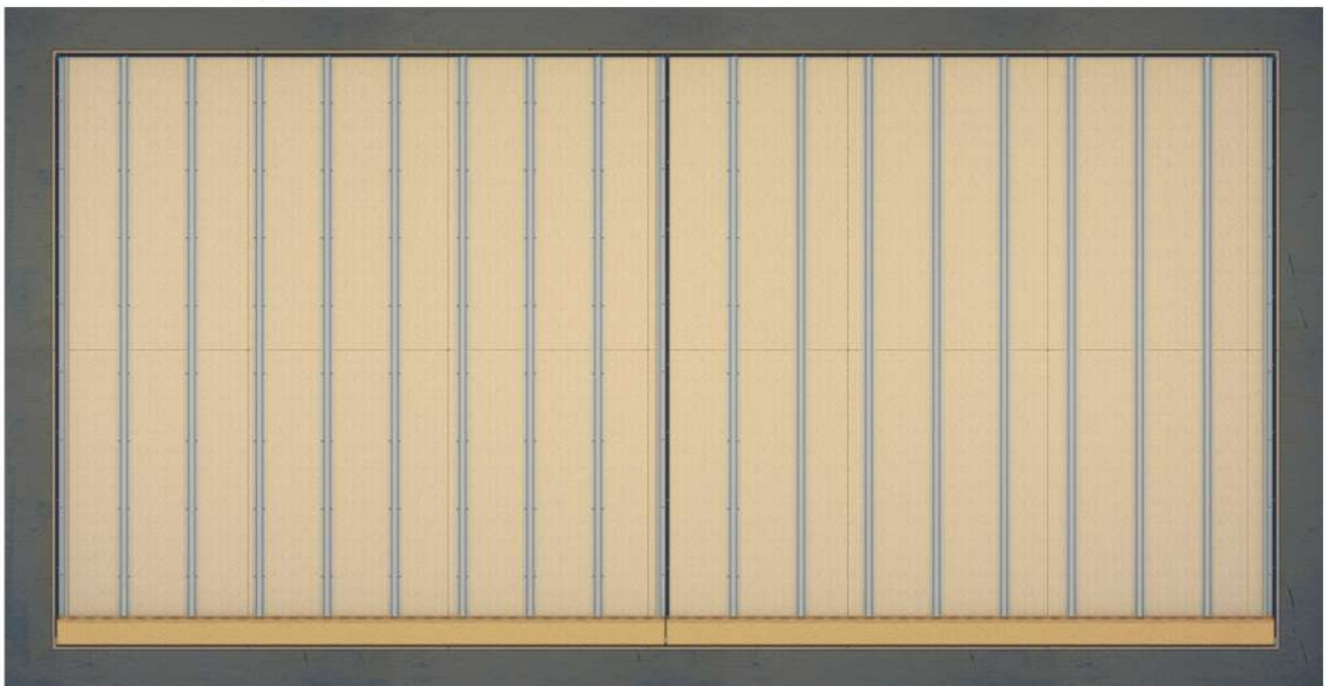
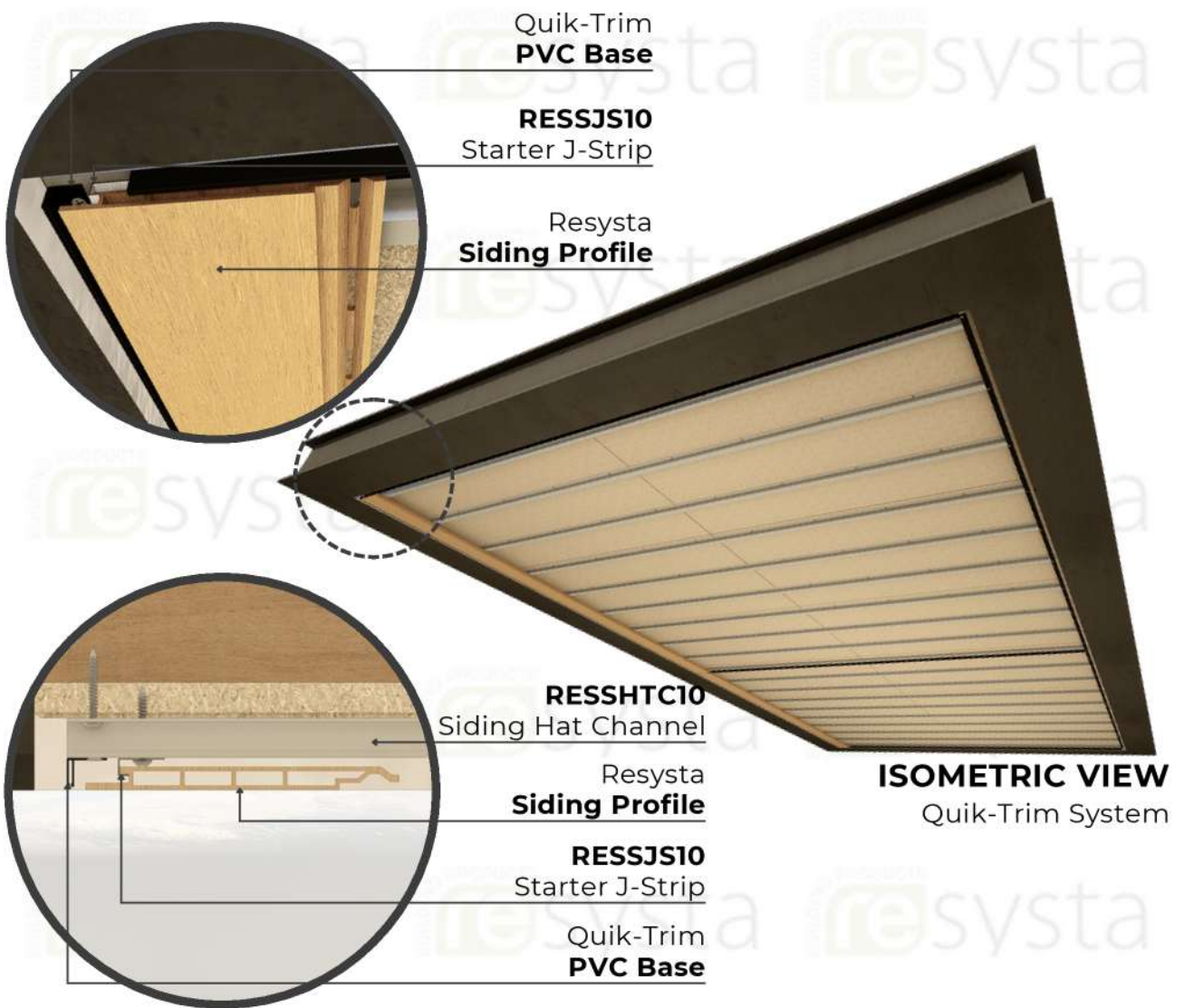

### DETAIL 1

Slide down the first Resysta Siding board into Starter J-Strip.



### DETAIL 2

Hook the groove end of the first Resysta Siding board into the Starter J-Strip with SS screw.



### DETAIL 3

Push the Resysta Siding board perpendicular into the joist and screw direct to the groove.



## STEP 6.5

Install the shoulder SS screws RESCPSS25 into all slotted holes except the center hole. DO NOT over-tighten the screws. The screws should be placed in the center of the slotted hole and loose enough to allow the board to move freely from side to side to allow for expansion and contraction.

**RESSHTC10**  
Siding Hat Channel

RESYSTA  
**Siding Profile**

**RESCPSS25**  
Shoulder SS Screw

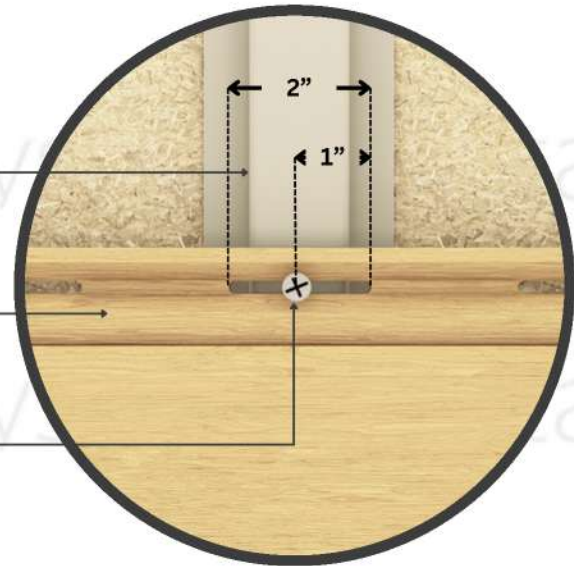

### ISOMETRIC DETAIL

Quik-Trim System

No Screw

**RESCPSS25**  
Shoulder SS Screw

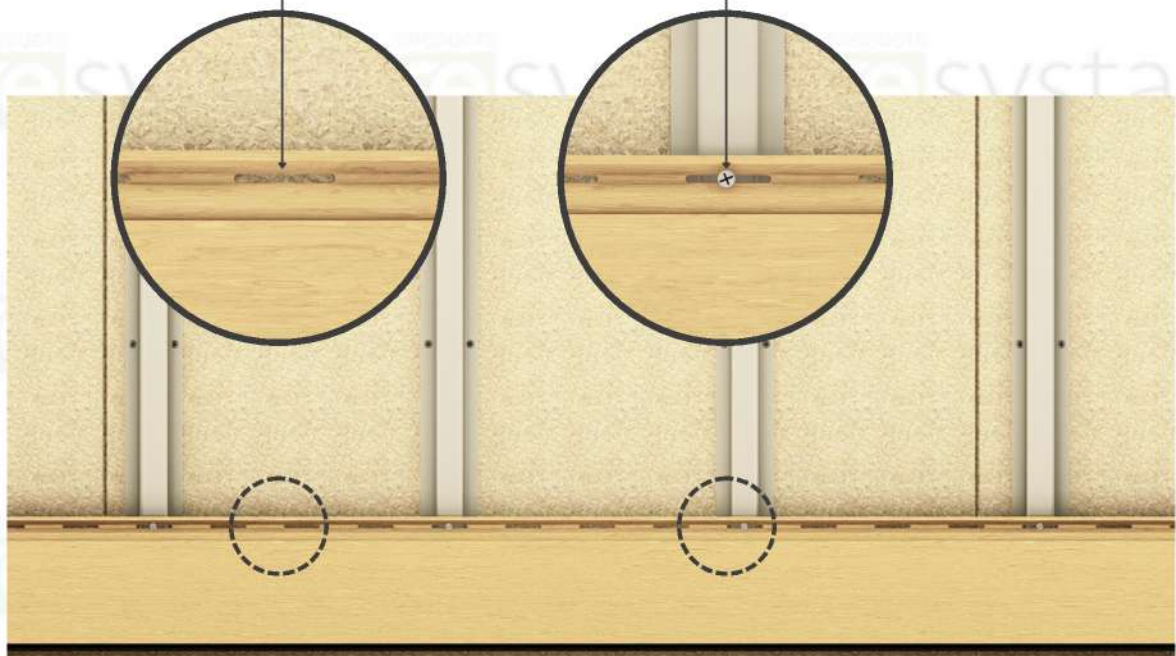

### REFLECTED CEILING PLAN

Quik-Trim System

#### Note

If installing more than one board in width, please refer to Section 7 – Horizontal Multi Board Siding Applications

## STEP 6.6

Install the final two RESCPSS25 screws in the slotted hole in the center of the board. This will allow for expansion and contraction evenly to each side of the assembly. Check the instruction pinning location in Section 8.

**RESSHTC10**

Siding Hat Channel

RESYSTA

**Siding Profile**

**RESCPSS25**

Shoulder SS Screw

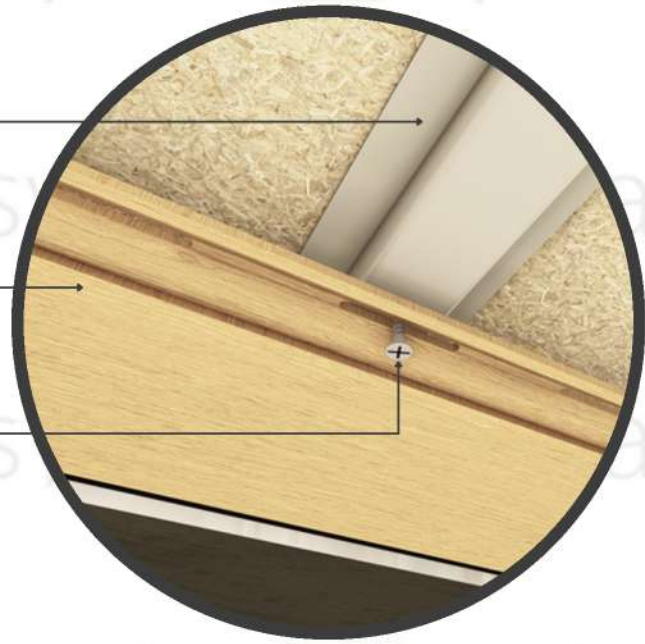

**ISOMETRIC DETAIL**

Quik-Trim System

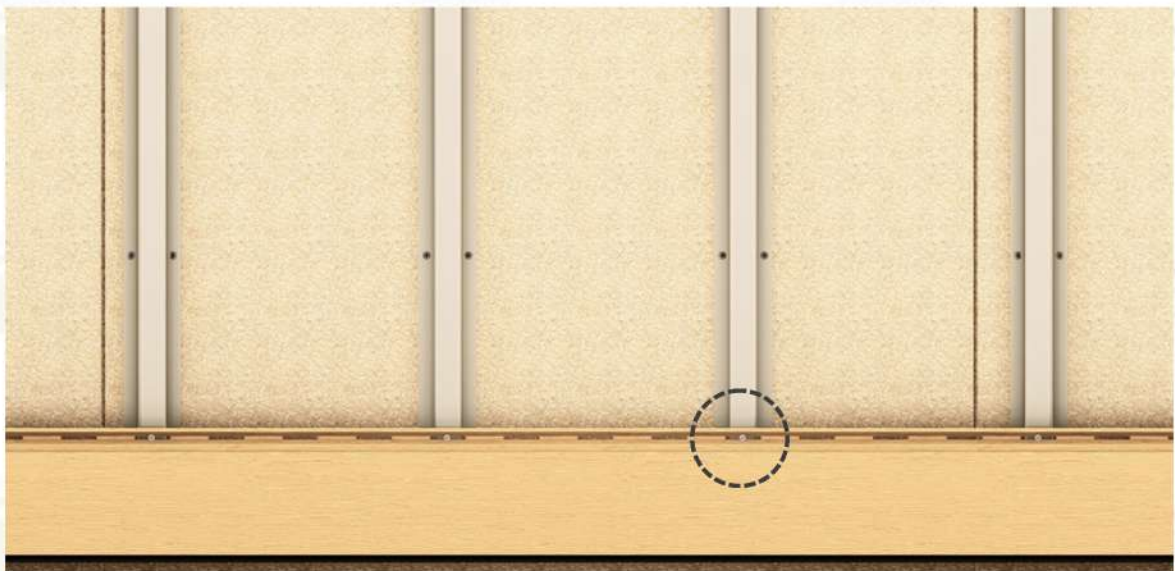

**REFLECTED CEILING PLAN**

Quik-Trim System

## STEP 6.7

Hook the groove end of the next board onto the tongue of the installed siding board.

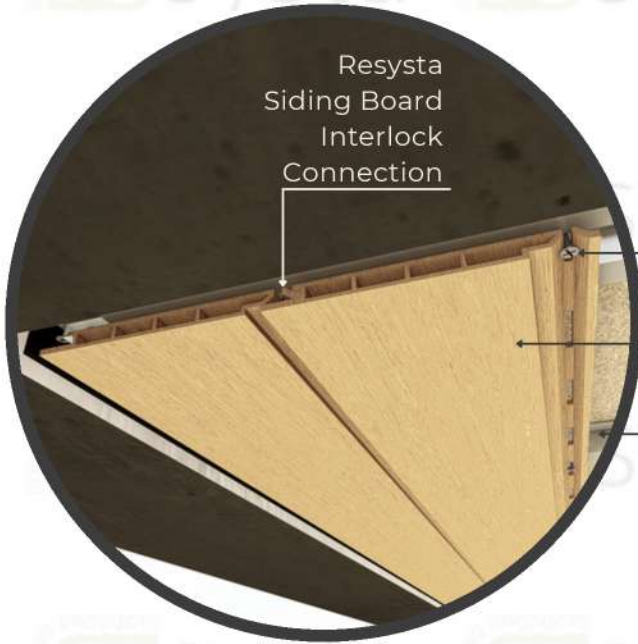

Resysta  
Siding Board  
Interlock  
Connection

**RESCPSS25**  
Shoulder SS Screw

**RESYSTA**  
Siding Profile

**RESSHTC10**  
Siding Hat Channel

### ISOMETRIC DETAIL

Quik-Trim System

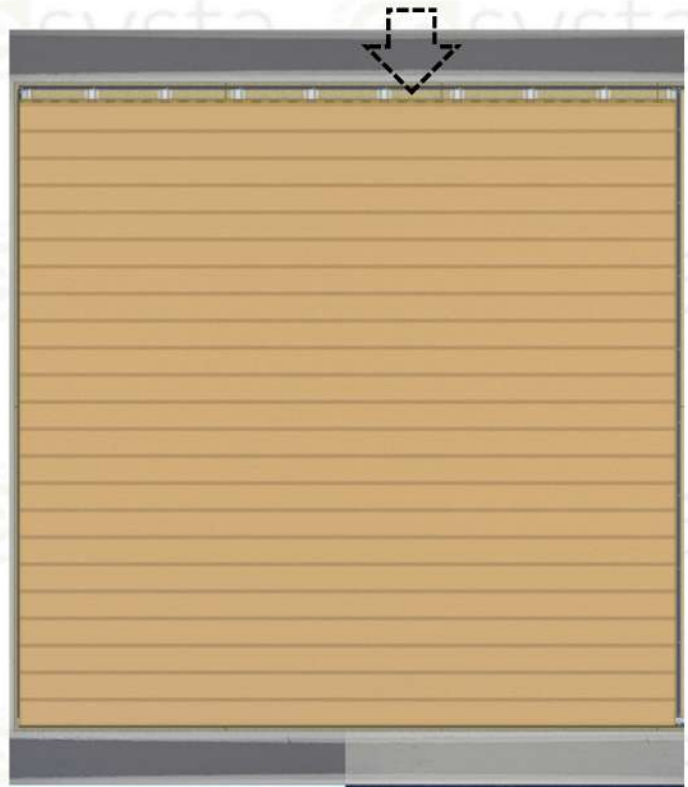

Thermal  
expansion hole



### DETAIL

Quik-Trim System

### REFLECTED CEILING PLAN

Quik-Trim System

## STEP 6.8

Continue installing siding boards as outlined in Section 3. Rip the last siding board into size to complete the siding.



## STEP 6.9

After the installation of the last Resysta siding board, the exposed siding edges will be finished by installing the aluminum Quik-Trim. Install the J-mold into the PVC base on all the perimeter / sides of the siding installation.



# SECTION 7 - Multi-Board Soffit and Ceiling Applications Resysta Runner Under Substructure Plywood

## 2 Board Wide Installation without the Aluminum Quik-Trim H-mold (24ft max width)

### STEP 7.1.1

Ensure that two battens have been installed horizontally where boards are to be installed end to end.

### STEP 7.1.2

Follow Steps 6.1, 6.2, and 6.3 from Section 6 to install the finishing trim, starter J-strip, and hook in the 1st siding board.

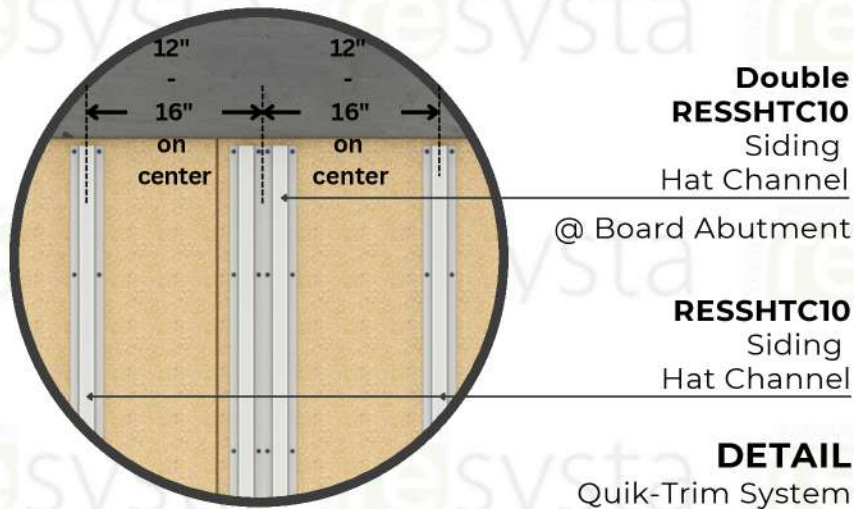

Quik-Trim  
**PVC Base**

**Double RESSHTC10 Siding Hat Channel**

Reverse  
**RESSHTC10 Siding Hat Channel**

**RESSHTC10 Siding Hat Channel**

**RESSJS10 Starter J-Strip**

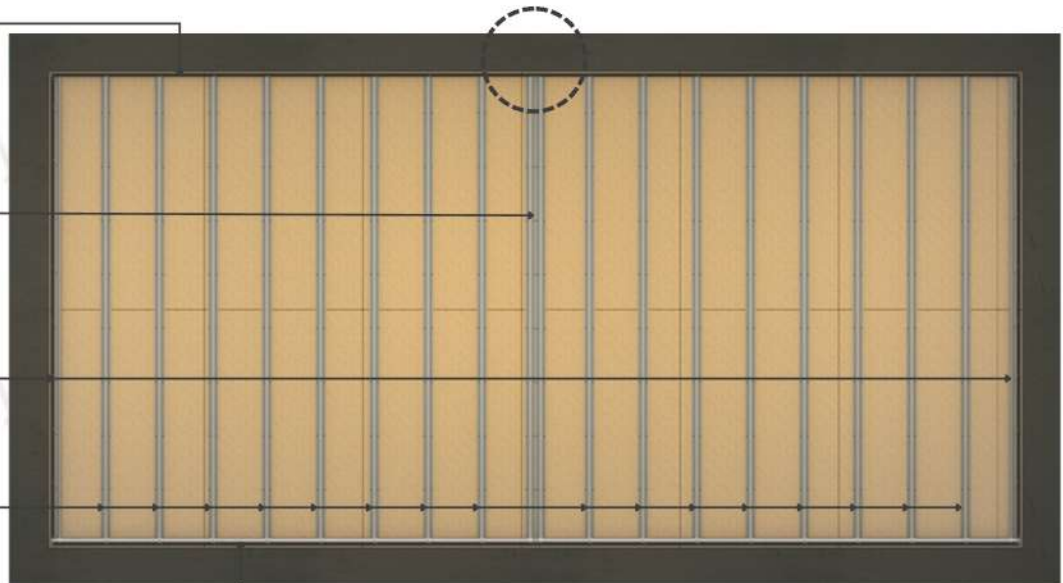

**REFLECTED CEILING PLAN**  
Quik-Trim System

### STEP 7.1.3

Install RESCPSS25 screws into all slotted holes except the hole closest to the abutted joint on both siding boards. DO NOT over-tighten the screws. The screws should be placed in the center of the slotted hole and loose enough to allow the board to move freely from side to side to allow for expansion and contraction.

Quik-Trim

**PVC Base**

Reverse

**RESSHTC10**

Siding

Hat Channel

**Double**

**RESSHTC10**

Siding

Hat Channel

**RESSHTC10**

Siding

Hat Channel



### REFLECTED CEILING PLAN

Quik-Trim System

**Double**  
**RESSHTC10**

Siding

Hat Channel

RESYSTA  
**Siding Profile**

**RESSHTC10**

Siding

Hat Channel

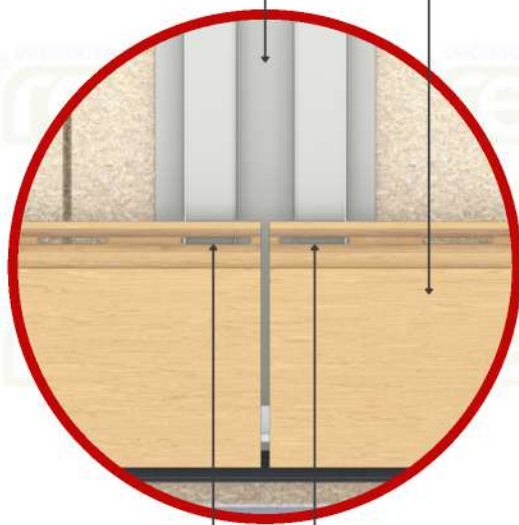

**No**  
**Fastener**

### DETAIL

@ Board Abutment  
Quik-Trim System

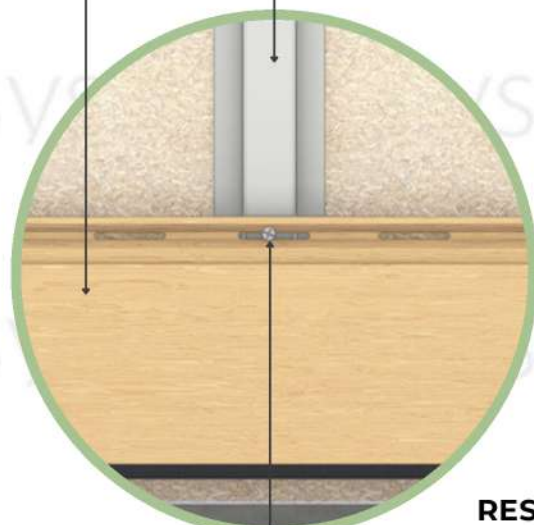

**RESCPSS25**  
Shoulder SS Screw

### DETAIL

Rest of Slotted Holes  
Quik-Trim System

### STEP 7.1.4

Install one RESCPSS25 screw in the slotted hole closest to the abutted joint on both siding boards. This will control expansion and contraction evenly to the outside of the siding boards while keeping the abutting joint snug.

Quik-Trim  
PVC Base

Reverse  
RESSHTC10  
Siding  
Hat Channel

Double  
RESSHTC10  
Siding  
Hat Channel

RESSHTC10  
Siding  
Hat Channel

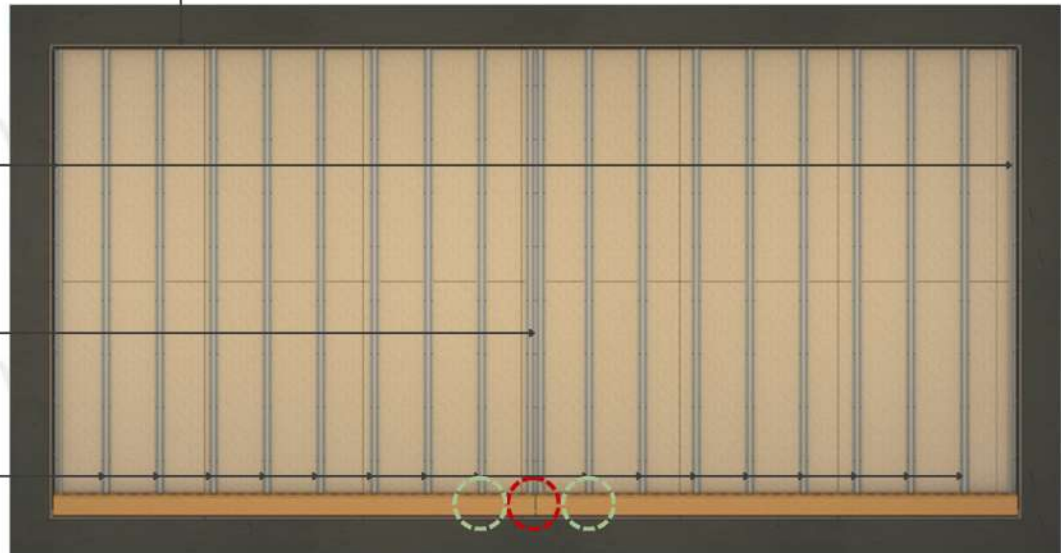

### REFLECTED CEILING PLAN

Quik-Trim System

Double  
RESSHTC10  
Siding  
Hat Channel

RESYSTA  
Siding Profile

RESSHTC10  
Siding  
Hat Channel

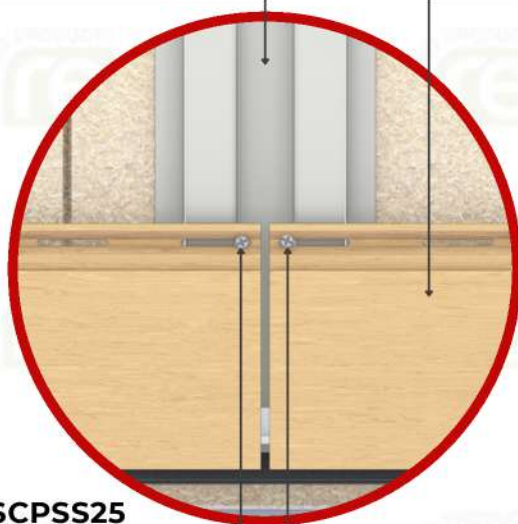

RESCPSS25  
Shoulder SS Screw

### DETAIL

@ Board Abutment  
Quik-Trim System

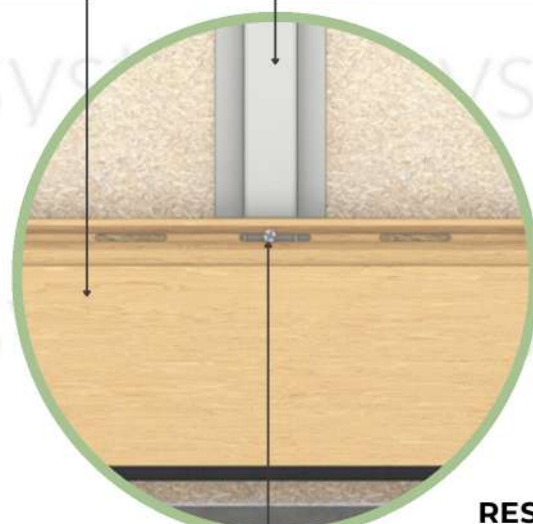

RESCPSS25  
Shoulder SS Screw

### DETAIL

Rest of Slotted Holes  
Quik-Trim System

### STEP 7.1.5

Hook the groove end of the next board onto the tongue of the installed siding board.

### STEP 7.1.6

Continue installing siding boards as outlined in Section 7: "2 Board Wide Installation without the Aluminum Quik-Trim H-mold" and follow steps 6.8 and 6.9 in Section 6 to finish the installation.

## Multi-Board Wide Installation using Continuous Aluminum Quik-Trim H-mold

### STEP 7.2.1

Follow Steps 3.1, 3.2 and 3.3 from Section 3.

### STEP 7.2.2

Install the Quik-Trim PVC base into the hat channel where the aluminum Quik-Trim H-mold will be installed.



Quik-Trim PVC Base

Reverse RESSHTC10 Siding Hat Channel

RESSHTC10 Siding Hat Channel

RESSJS10 Starter J-Strip

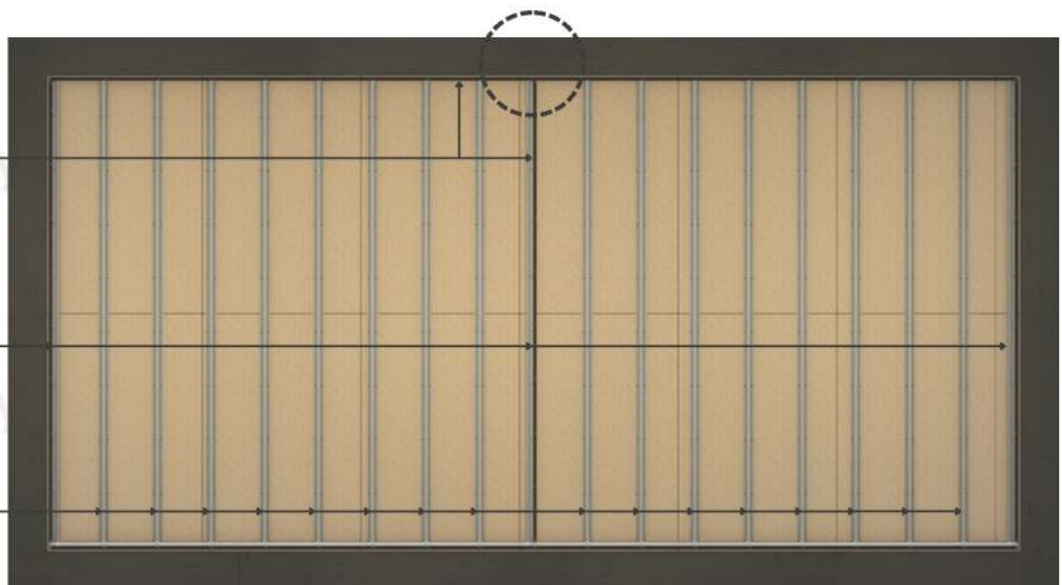

**REFLECTED CEILING PLAN**  
Quik-Trim System

Quik-Trim  
PVC Base

Reverse  
**RESSHTC10**  
Siding  
Hat Channel

**RESSHTC10**  
Siding  
Hat Channel

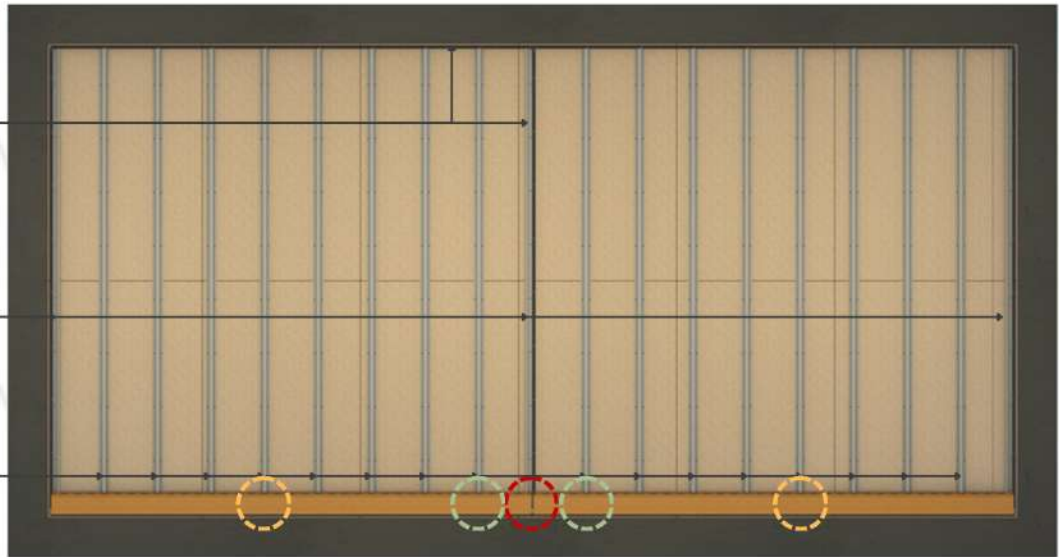

## REFLECTED CEILING PLAN

Quik-Trim System

### STEP 7.2.3

Follow steps 6.4, 6.5, and 6.6 of Section 6 and install RESCPSS25 screws or #8 screws into all slotted holes except the center hole. DO NOT over-tighten the screws. The screws should be placed in the center of the slotted hole and loose enough to allow the board to move freely from side to side to allow for expansion and contraction.

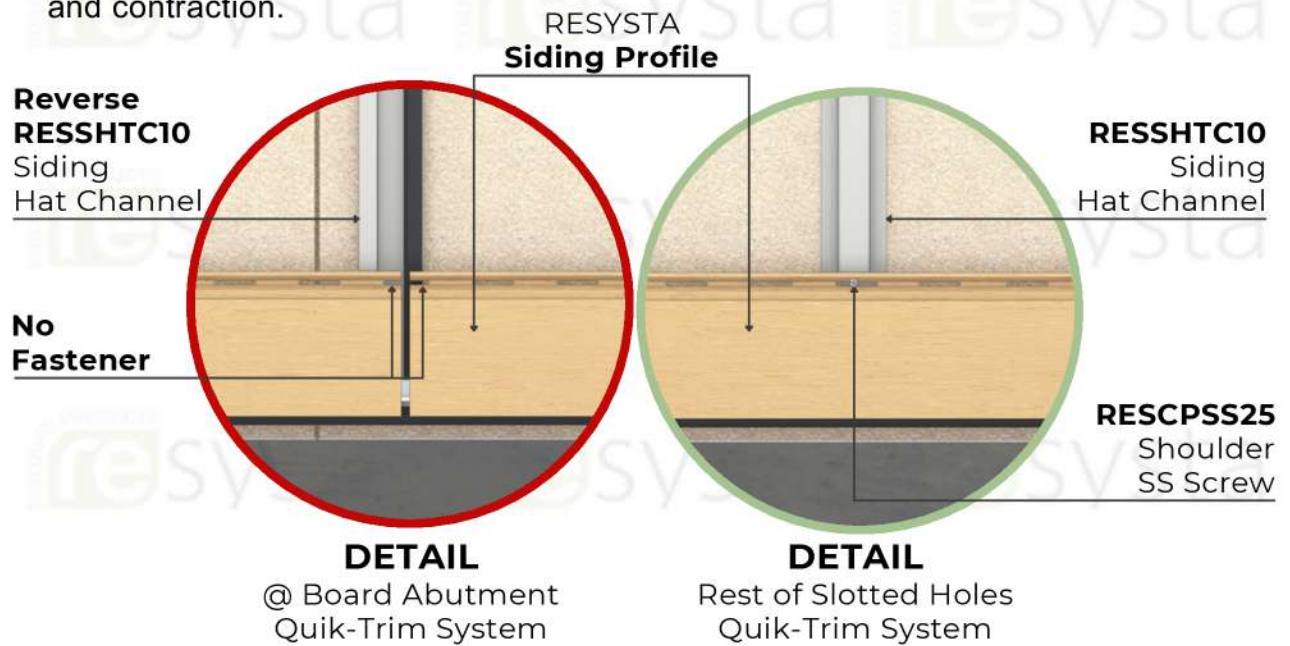

### STEP 7.2.4

Install the final two RESCPSS25 screws closest to the ends in the slotted hole in the center of the board. This will allow for expansion and contraction evenly to each side of the assembly.

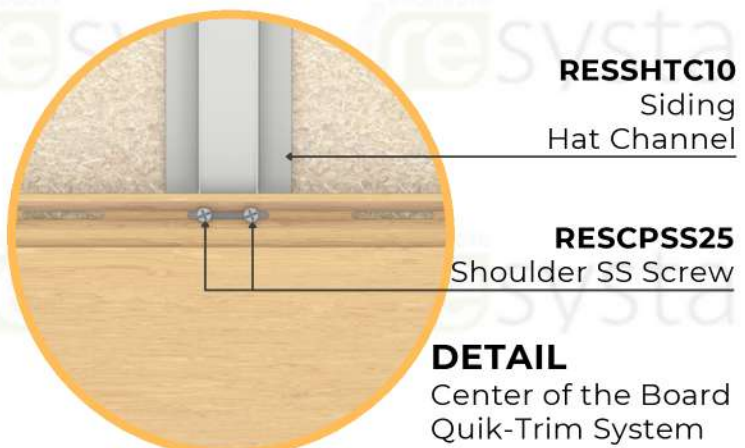

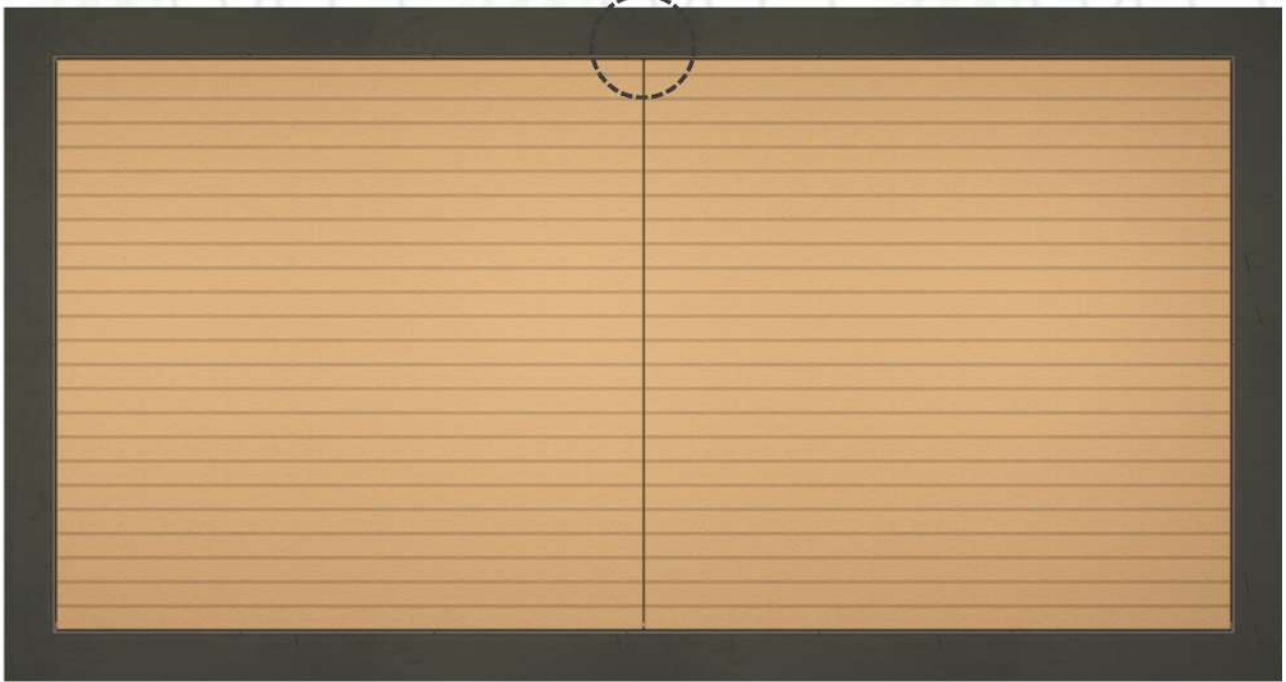

**REFLECTED CEILING PLAN**  
Quik-Trim System

**Reverse**  
**RESSHTC10**  
Siding  
Hat Channel

Quik-Trim  
**PVC Base**

RESYSTA  
**Siding Profile**



**DETAIL**  
Quik-Trim System

## STEP 7.2.5

After the installation of the last siding board, finally install all the aluminum trim on the PVC base to finish the installation.

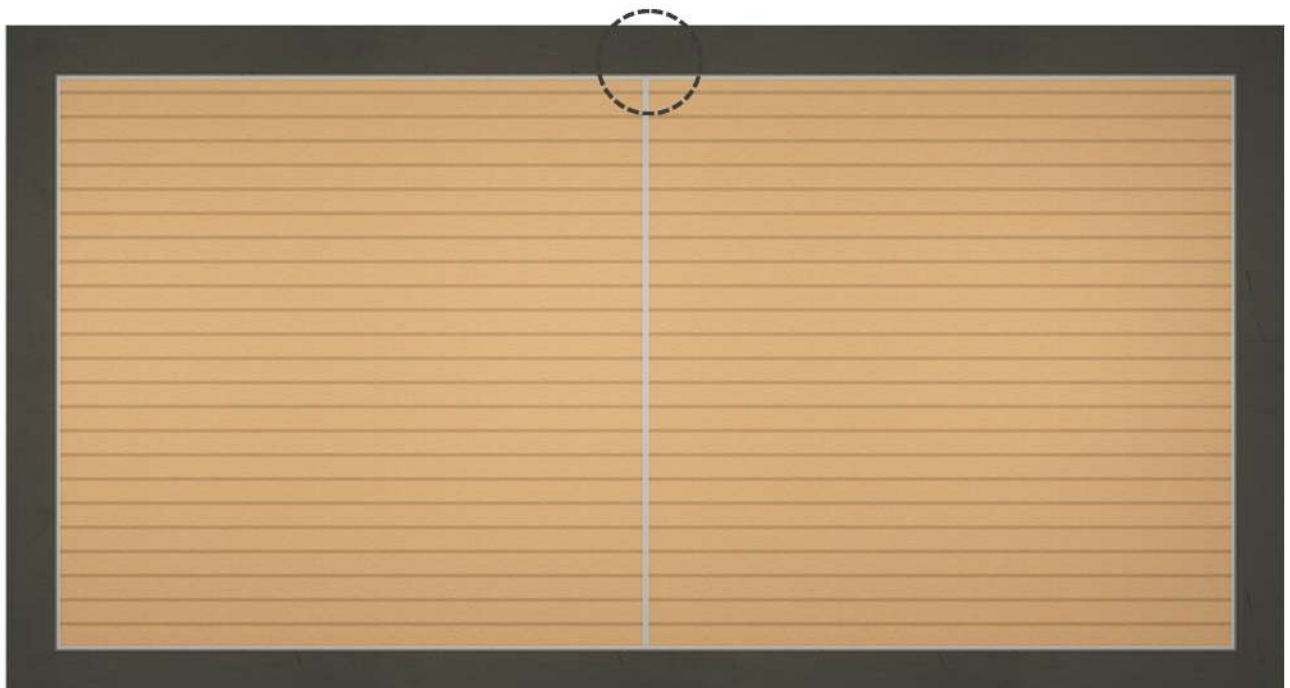
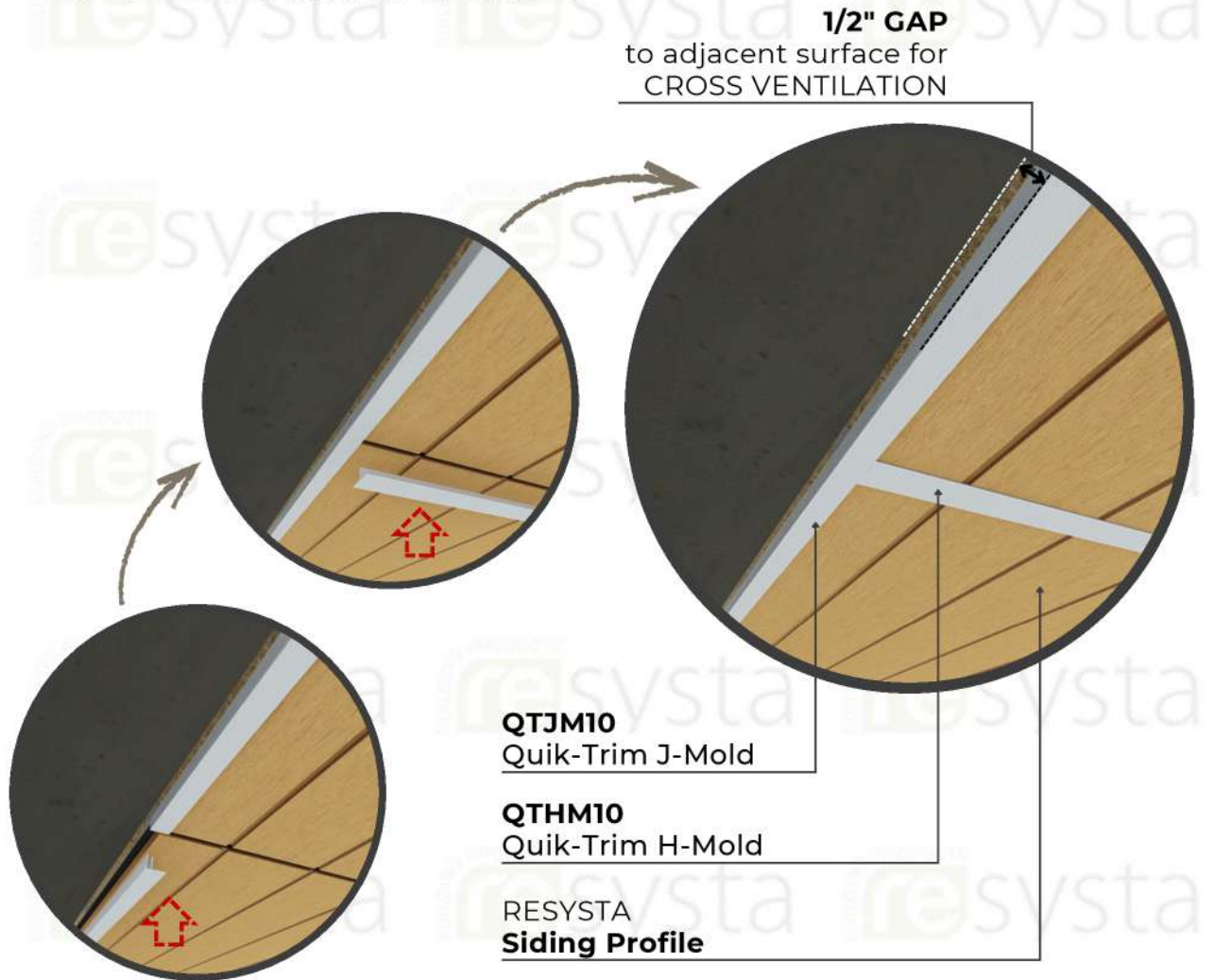

**REFLECTED CEILING PLAN**  
Quik-Trim System

## SECTION 8 – BOARD TERMINATION TRIM

When a siding board on eaves and ceiling in either a horizontal or vertical application terminates into a wall, fascia eave, etc. a Quik-Trim J-mold should be used to cover the exposed end of the siding board. The Quik-Trim J-mold should also be used along the bottom of an opening installation. The Quik-Trim PVC base should be pre-applied prior to installing siding boards. In the case of an intersecting joint, the starter strip should be installed butted against the Quik-Trim PVC base, not overlapping the Quik-Trim J-mold trim attachment flange. Follow the gap guide when installing the siding board to allow for expansion and contraction within the Quik-Trim J-mold trim.

### HORIZONTAL / VERTICAL APPLICATION

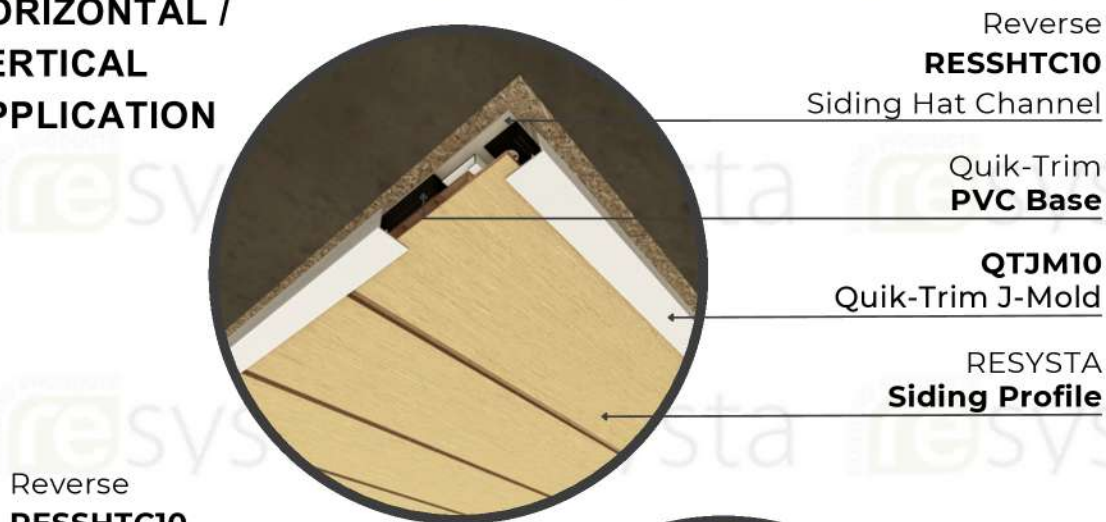

Reverse  
**RESSHTC10**  
Siding Hat Channel

Quik-Trim  
**PVC Base**

**QTJM10**  
Quik-Trim J-Mold

RESYSTA  
**Siding Profile**

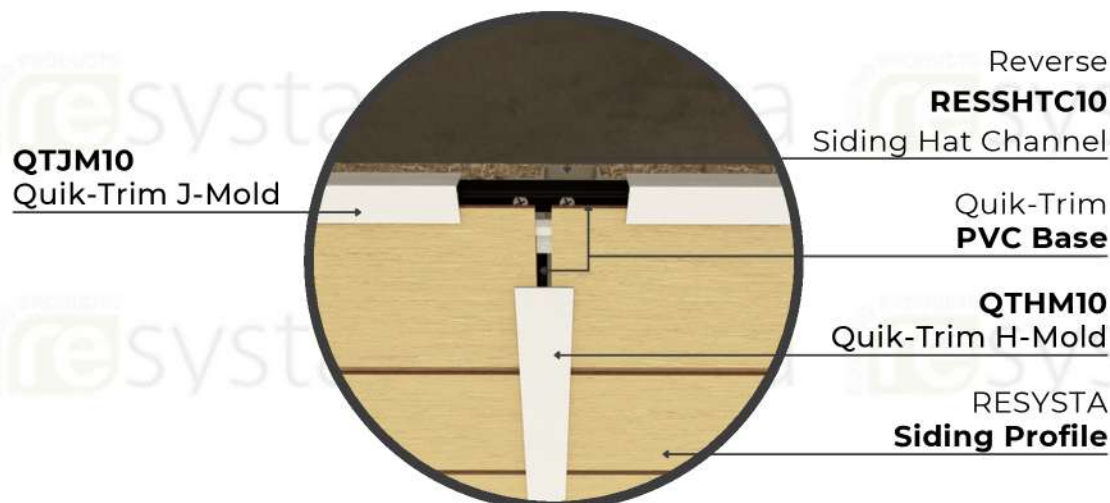

**QTJM10**  
Quik-Trim J-Mold

Reverse  
**RESSHTC10**  
Siding Hat Channel

Quik-Trim  
**PVC Base**

**QTHM10**  
Quik-Trim H-Mold

RESYSTA  
**Siding Profile**

## SECTION 9 – PINNING

**Pinning** is a way to control the direction of expansion of the Resysta Siding board, each board needs to be fixed at one end of the board.

**Option 01** Every board should hard pin on one end of Resysta Siding board to allow one side expansion direction.

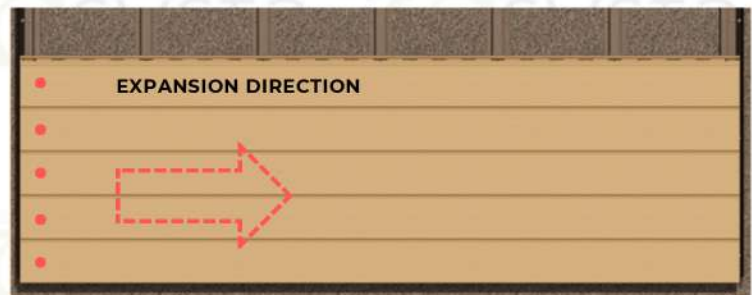

Pinning the RESCPSS25  
Stainless Steel Screw at  
the first hole of the  
Resysta Siding board.

**Option 02** Every board should hard pin on the middle of the Resysta Siding board to allow for right or left side expansion direction.

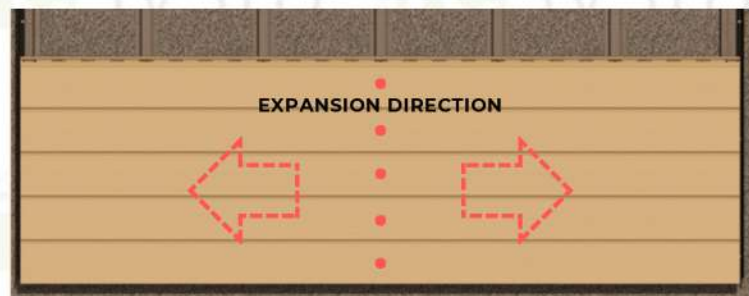

Pinning the RESCPSS25  
Stainless Steel Screw at  
the middle hole of  
Resysta Siding board.

## SECTION 10 – Primer and Sealer System

Resysta recommends using an approved water-based primer RBP and stain RCL system.

### III. SAFETY WARNING

Resysta® Products do not present an inhalation, ingestion, or contact health hazard unless subjected to operations such as sawing, sanding, or machining which result in the generation of airborne particulate. This product contains amorphous silica. Respirable amorphous silica limits are specified by OSHA. Exposure to respirable (fine) silica dust depends on a variety of factors, including activity rate (e.g. cutting rate), method of handling, ventilation, environmental conditions (e.g. weather conditions, workstation orientation), and engineering control measures used. Exposures to respirable amorphous silica above limits established by OSHA are not expected during the normal use of this product. Amorphous silica has been shown to cause silicosis and has been identified by the State of California, IARC, and NTP as a known human carcinogen. The risk of developing silicosis is dependent upon the exposure intensity and duration. It is recommended that a NIOSH-approved particulate respirator be worn whenever working with this product results in airborne dust exposure.

**Please direct product inquiries to:**

Resysta North America, Inc.  
4035 Cheyenne Ct.  
Chino, CA. 91710  
Tel: 909-393-2888  
Email: [info@resystausa.com](mailto:info@resystausa.com)